

L9系列

凸耳式蝶阀

Lug butterfly valve



DOWNLOAD
DATASHEET



b-Smart, Be-Brandoni



www.brandonivalves.it

brandoni
VALVES

凸耳式蝶阀 / Lug butterfly valve

L9系列凸耳式隔断蝶阀，带有中心式阀板和凸耳式阀体，阀体材质为球铁，严格按照相关产品质量标准生产，符合EN ISO 9001标准。

适用于供热和空调系统，供水和水处理系统以及工业、农业系统。介质可以是水、压缩空气、燃气、油类及碳氢化合物。

(请确保您的选择与适用范围一致)

YES: 可安装于管路中部及末端，可频繁开启。上法兰符合ISO 5211标准。可以安装各种执行器和驱动器。

可以用于切断和调节流体。

NO: 不适用于蒸汽系统。

附件

- 用于连接给水总管系统的阀杆延长装置
- 位置指示器和齿轮箱挂锁
- 齿轮箱限位开关
- 用来指示开关位置的限位开关

驱动器

- 气动执行器：单作用/双作用
- 可定制：限位开关，位置指示器
- 电动执行器
- 齿轮箱
- 链条驱动

认证 / Certifications

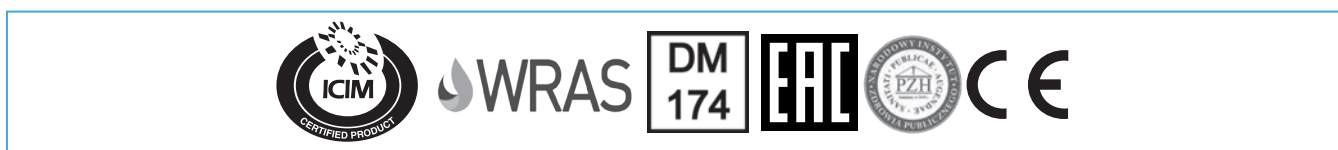

符合2014/68/UE PED (ex 97/23/CE) 标准

符合D.M. 174 (98/83/CE指令) 标准和UNI EN 1074-1:2001 - UNI EN 1074-2:2004 标准

结构及检测标准:

结构长标准: EN558/1-20 (ISO 5752-20, DIN 3202K1)

法兰标准: EN1092 ISO 7005, ANSI B16.5 #150

设计标准: EN593, EN12516, ISO 5211, EN12570

标识标准: EN19

检测标准: EN 12266 cat. A (ISO 5208 cat. A)

The shut-off LUG butterfly valves in Series L9, with a centred Disc and LUG type body, are made of ductile iron, manufactured in accordance with severe product norms and in conformity to EN ISO 9001.

These valves are suitable for heating and conditioning (HVAC), water treatment and water distribution, industrial applications, agricultural purposes, for compressed air, gas, oils and hydrocarbon.

(Please ensure the choice of the corresponding item)

YES: for in line and end of line installation with frequent actuation; the integrated support, in accordance with ISO 5211, allows easy mounting of a wide range of actuators and drives.

They are suitable for choking and regulating the flow.

NO: for steam.

Accessories

- Extension for main water system connection
- Position indicator and padlocking for gear box
- Micro-switch for gear box
- Kit: micro-switches for ON/OFF position indicator

Actuators

- Double acting and single acting pneumatic actuators
- On request: micro-switches, position indicators
- Electric actuators
- Gear box
- Chain driven control

In conformity with directive 2014/68/UE (ex 97/23/CE PED)

In conformity with D.M. 174 (directive 98/83/CE) and with UNI EN 1074-1:2001 - UNI EN 1074-2:2004

Design and testing standards (correspondences):

Face-to-face: EN558/1-20 (ISO 5752-20, DIN 3202K1)

Flanges: EN1092 ISO 7005, ANSI B16.5 #150

Design: EN593, EN12516, ISO 5211, EN12570

Marking: EN19

Testing: 100% testing in accordance with EN 12266 cat. A (ISO 5208 cat. A)

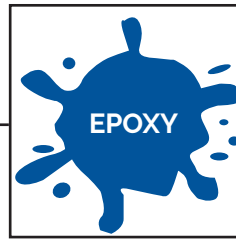

内外环氧树脂喷涂，耐高温。环保水性涂料。涂层厚度为150 μ。

Inside and outside epoxy coating, high temperature resistant. Environmentally friendly, water-based paint. 150 μ thickness.

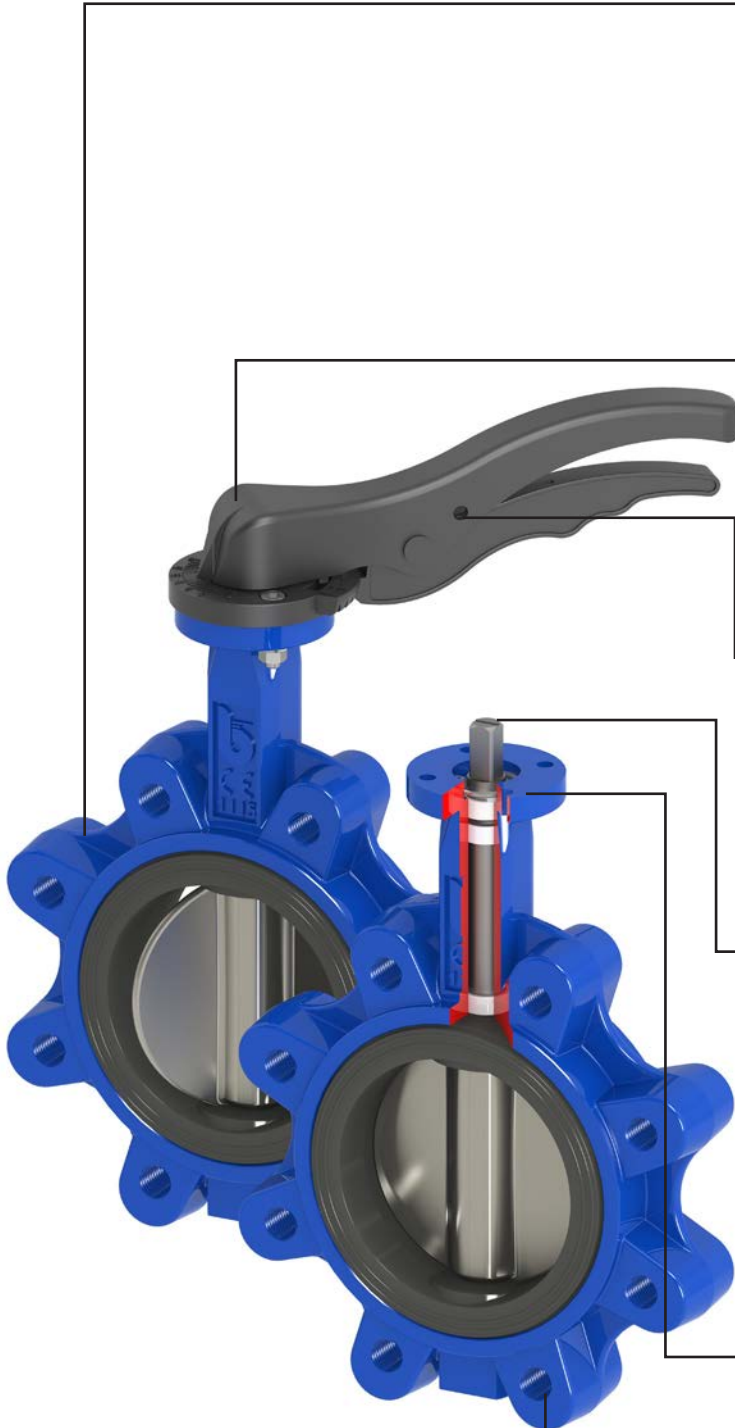

副手柄可以锁定在任意刻度，利于调节流量。

Lever suitable for intermediate regulation.

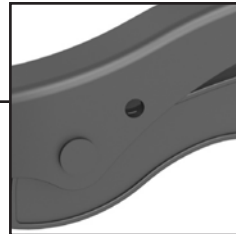

可锁定的操作手柄。

Lockable operation lever.

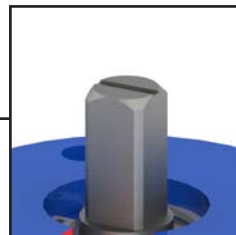

阀杆顶部设有一个指示蝶板位置的凹槽，确保手柄或驱动器移去后仍能准确判断阀门开合，以将手柄或驱动器准确装回。

A notch machined at the top of the stem indicates the position of the disc and allows adjusting the lever/actuator to the correct position, when the command/lever is removed.

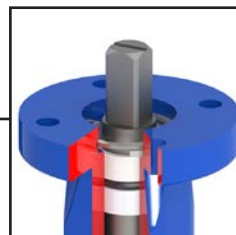

ISO 5211标准上法兰。

Integrated ISO 5211 flange.

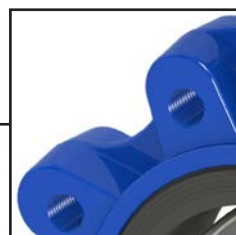

DN25-300: 连接孔可连接PN16法兰
DN350-600: 连接孔可连接PN10法兰

Threaded holes suitable for mounting between PN16 for DN25-300 flanges (on request PN 10) and for mounting between PN 10 for DN 350-600 flanges.

EPDM



L9.100

阀体: EN GJS 400-15
 阀板: EN GJS 400 镀锌
 阀座: EPDM
 工作温度: -10 + 120 °C

Body: ductile iron
 Disc: nickel plated ductile iron
 Liner: EPDM
 Temp: -10 a +120°C



L9.120

阀体: EN GJS 400-15
 阀板: AISI 316
 阀座: EPDM
 工作温度: -10 + 120 °C

Body: ductile iron
 Disc: AISI 316
 Liner: EPDM
 Temp: -10 a +120°C



L9.128

阀体: EN GJS 400-15
 阀板: AISI 316
 阀座: EPDM
 工作温度: -10 + 120 °C
Wras认证水温最高80 °C

Body: ductile iron
 Disc: AISI 316
 Liner: EPDM
 Temp: -10 a +120°C
Wras approv. up to 80° C



L9.170

阀体: EN GJS 400-15
 阀板: 铝青铜
 阀座: EPDM
 工作温度: -10 + 120 °C

Body: ductile iron
 Disc: Aluminium-bronze
 Liner: EPDM
 Temp: -10 a +120°C

NBR



L9.101

阀体: EN GJS 400-15
 阀板: EN GJS 400 镀锌
 阀座: NBR
 工作温度: -10 + 80 °C

Body: ductile iron
 Disc: nickel plated ductile iron
 Liner: NBR
 Temp: -10 a +80°C



L9.101 gas

阀体: EN GJS 400-15
 阀板: EN GJS 400 镀锌
 阀座: NBR
 工作温度: -10 + 70 °C

Body: ductile iron
 Disc: nickel plated ductile iron
 Liner: NBR
 Temp: -10 a +70°C



L9.121

阀体: EN GJS 400-15
 阀板: AISI 316
 阀座: NBR
 工作温度: -10 + 80 °C

Body: ductile iron
 Disc: AISI 316
 Liner: NBR
 Temp: -10 a +80°C



L9.121 gas

阀体: EN GJS 400-15
 阀板: AISI 316
 阀座: NBR
 工作温度: -10 + 70 °C

Body: ductile iron
 Disc: AISI 316
 Liner: NBR
 Temp: -10 a +70°C

NBR



L9.171

阀体: EN GJS 400-15
 阀板: 铝青铜
 阀座: NBR
 工作温度: -10 + 80 °C

Body: ductile iron
 Disc: Aluminium-bronze
 Liner: NBR
 Temp: -10 a +80°C



L9.102

阀体: EN GJS 400-15
 阀板: EN GJS 400 镀锌
 阀座: FKM
 工作温度: -10 + 150 °C

Body: ductile iron
 Disc: nickel plated ductile iron
 Liner: FKM
 Temp: -10 a +150°C



L9.122

阀体: EN GJS 400-15
 阀板: AISI 316
 阀座: FKM
 工作温度: -10 + 150 °C

Body: ductile iron
 Disc: AISI 316
 Liner: FKM
 Temp: -10 a +150°C



L9.172

阀体: EN GJS 400-15
 阀板: 铝青铜
 阀座: FKM
 工作温度: -10 + 150 °C

Body: ductile iron
 Disc: Aluminium-bronze
 Liner: FKM
 Temp: -10 a +150°C

PTFE



L9.103

阀体: EN GJS 400-15
阀板: EN GJS 400 镀铬
阀座: PTFE
工作温度: $-10 + 120^{\circ}\text{C}$

*Body: ductile iron
Disc: nickel plated ductile iron
Liner: PTFE
Temp: $-10 \text{ a } +120^{\circ}\text{C}$*



L9.123

阀体: EN GJS 400-15
阀板: AISI 316
阀座: PTFE
工作温度: $-10 + 120^{\circ}\text{C}$

*Body: ductile iron
Disc: AISI 316
Liner: PTFE
Temp: $-10 \text{ a } +120^{\circ}\text{C}$*



L9.173

阀体: EN GJS 400-15
阀板: 铝青铜
阀座: PTFE
工作温度: $-10 + 120^{\circ}\text{C}$

*Body: ductile iron
Disc: Aluminium-bronze
Liner: PTFE
Temp: $-10 \text{ a } +120^{\circ}\text{C}$*

凸耳式蝶阀 / Lug butterfly valve

驱动器和附件 / Actuators and accessories

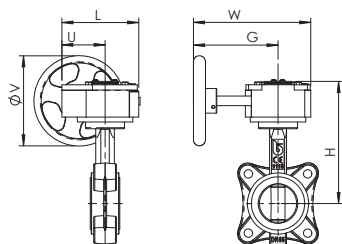

L9 + RM

齿轮箱

Gear box

DN	25	32	40	50	65	80	100	125	150	200	250	300	350	400	450	500	600
L9 + RM	RM.0250	RM.0250	RM.0250	RM.0250	RM.0250	RM.0250	RM.0250	RM.0250	RM.0250	RM.0750	RM.1200	RM.1200	RM.1200	3DE-180	3DE-180	3DE-250	3DE-400
L	130	130	130	130	130	130	130	130	130	180	205	205	205	278	278	277	323
U	77	77	77	77	77	77	77	77	77	104	124	124	124	118	118	107	131
H	166	172	178	188	198	212	232	242	262	308	346	372	448	497	519	607	693
W	225	225	225	225	225	225	225	225	225	338	345	345	345	291	291	379	428
F	170	170	170	170	170	170	170	170	170	260	260	260	260	167	167	207	256
V	150	150	150	150	150	150	150	150	150	300	300	300	300	380	380	285	385
重量 / Weight Kg	6.6	6.6	6.3	7.2	8.1	9.22	10.52	12.91	14.11	28.4	42	50.5	79.3	122.6	154.8	228.3	308.6

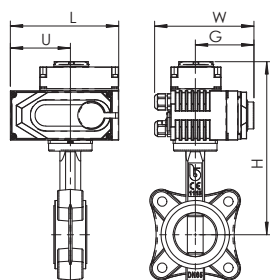

L9 + AOX

电动执行器

Electric actuators

DN	25	32	40	50	65	80	100	125	150	200	250	300
L9 + AOX	003	003	003	003	005	005	008	010	015	030	060	060
L	123	123	123	123	160	160	160	189	189	268	268	268
U	74	74	74	74	89	89	89	107	107	152	152	152
H	217	223	229	239	257	271	291	309	329	394	430	456
W	100	100	100	100	121	121	121	145	145	225	225	225
G	65	65	65	65	84	84	84	89	89	119	119	119
重量 / Weight Kg	4.7	4.7	4.4	5.3	7.7	9	10.3	14.2	15.4	34.5	46.5	52.2

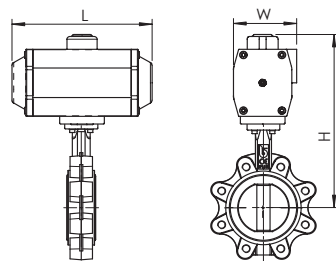

L9 + AP

气动执行器

Pneumatic actuator

DN	25	32	40	50	65	80	100	125	150	200	250	300	350	400
L9 + AP DE	AP1	AP1	AP2	AP2	AP3	AP3	AP3	AP3.5	AP4	AP4.5	AP5.5	AP5.5	AP6	AP8
L	142	142	155	155	213	213	213	236	276	310	388	388	468	563
H	191	197	219	229	256	270	290	310	345	402	472	498	565	740
W	60	60	73	73	85	85	85	98	110	128	160	160	175	215
重量 / Kg	3.6	3.6	3.72	4.62	6.64	7.94	9.24	13.28	15.9	29.34	46.64	55.14	77.24	120.54
L9 + AP SE - 弹簧复位 / SPRING RETURN	AP2S	AP2S	AP3S	AP3S	AP3.5S	AP3.5S	AP4S	AP4.5S	AP5S	AP6S	AP8S	AP8S	AP8S	AP10S
L	155	155	213	213	236	236	276	310	366	468	563	563	563	750
H	207	213	236	246	316	330	365	412	445	520	646	672	715	725
W	73	73	85	85	98	98	110	128	140	175	215	215	215	290
重量 / Weight Kg	4.16	4.16	5.4	6.3	8.4	9.7	12.9	19.27	23.42	44.96	77.52	86.02	108.12	207.6

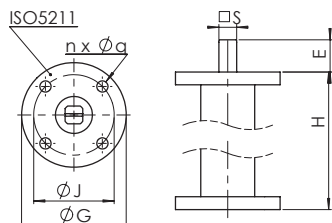

DN	40-100	125-150	200	250-300
H	250-500-800-1000			
ISO 5211	F05	F07	F10	F12
G	65	90	125	150
J	50	F07	F10	F12
n x Ø q	4 x 7	4 x 9	4 x 11	4 x 13
E	20	26	26	26
S	11	14	17	27

KPROg

用于连接给水总管系统的阀杆
延长装置

Stem extension for water
main system connection

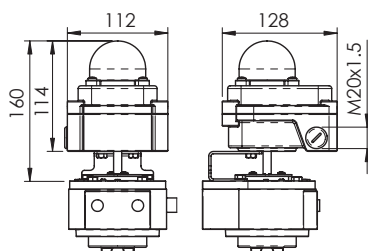
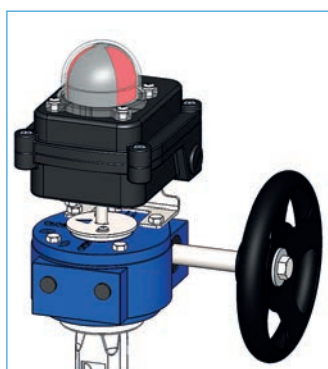

标准机械开关
可选：普通接近开关，防爆接近开关。

Mechanical switches per standard.
Available on request: proximity switches,
ATEX explosion proof proximity switches.

KBOXRM

齿轮箱限位开关

Limit switches box for gear
box

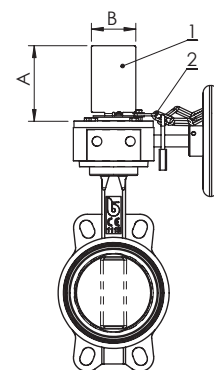
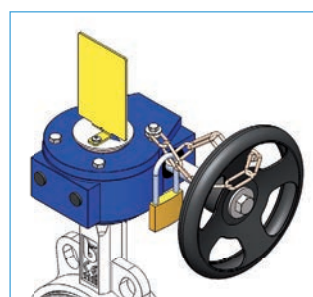

KPOSRM

位置指示器及齿轮箱挂锁
Position indicator and padlocking for gear box

DN	25-150	200-400
A	100	120
B	60	80

1) 位置指示器
2) 挂锁

1) Position indicator
2) Chain for padlocking

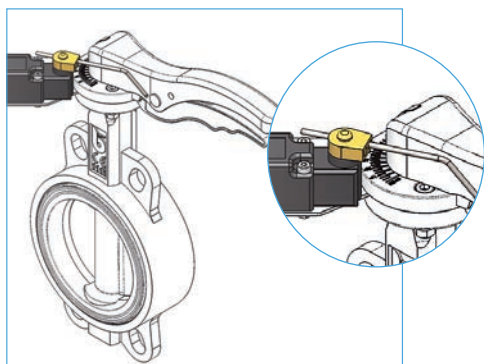

KFC109

用来指示开关位置的限位开关

Limit switches kit for ON-OFF indication

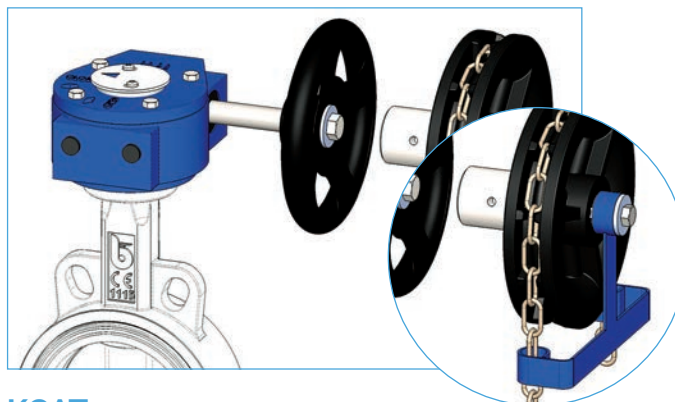

KCAT

链条驱动装置

Chain driver kit

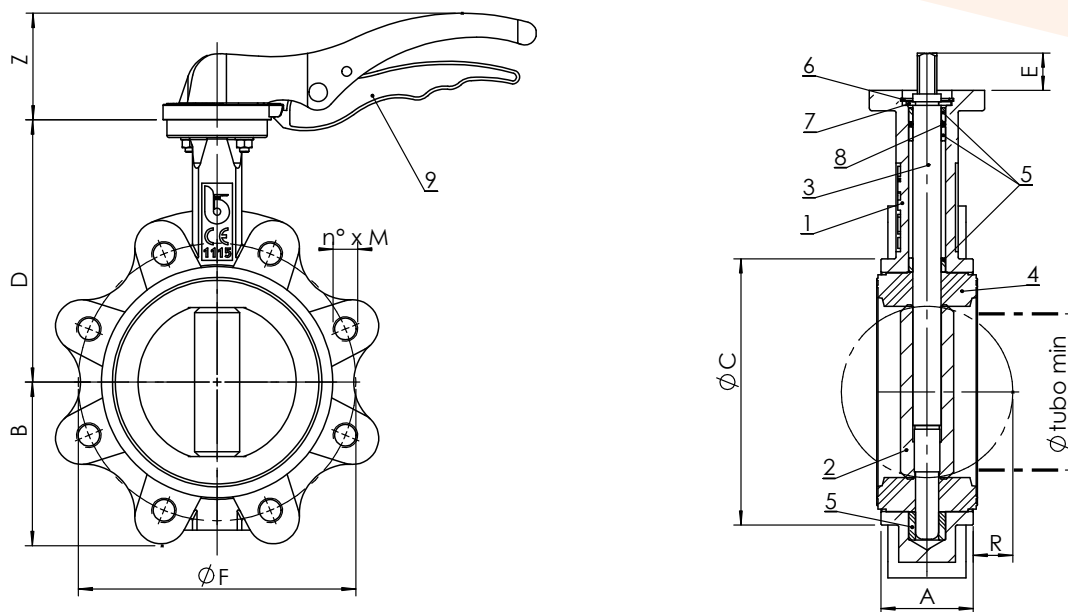

尺寸 (mm) / Dimensions (mm)

DN	25	32	40	50	65	80	100	125	150	200	250	300	350	400	450	500	600
A	33	33	33	43	46	46	52	56	56	60	68	78	78	102	114	127	154
ØC	65	73	82	89	102	118	150	174	205	260	318	376	438	489	539	594	695
D	104	110	116	126	136	150	170	180	200	230	266	292	368	400	422	480	562
B	51	56	63	62	69	90	106	119	131	166	202	235	267	297	318	355	444
F1	192	192	170	170	170	206	206	285	285	400	530	-	-	-	-	-	-
Z	68	68	50	50	50	69	69	90	90	72	72	-	-	-	-	-	-
R	-	1	5	5	9	17	26	34	50	71	91	112	128	144	163	182	219
ØY 最小管路直径 / min pipe	-	12	27	31	45	65	90	110	146	194	241	291	324	379	428	475	573

注意：带有 ≥ DN300 的 EPDM、NBR 和 FKM 阀座和 ≥ DN125 的 PTFE 阀座的阀门将配备手动异径管

NOTE: valves with EPDM, NBR and FKM ≥ DN 300 and those with PTFE ≥ DN 125 will be supplied with MANUAL REDUCER

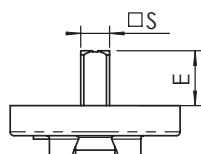
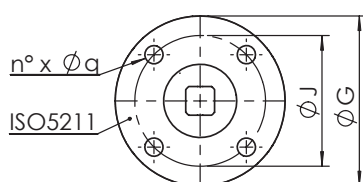

DN25-300

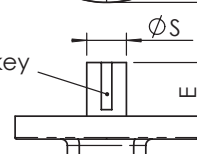
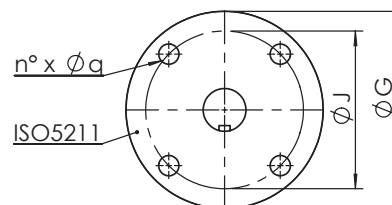

Chiavetta / Parallel key
ISO R773 / DIN6885A

DN350-600

DN	25	32	40	50	65	80	100	125	150	200	250	300	350	400	450	500	600
n x M	4 x M12	4 x M16	4 x M16	4 x M16	4 x M16	8 x M16	8 x M16	8 x M16	8 x M20	12 x M20	12 x M24	12 x M24	16 x M20	16 x M24	20 x M24	20 x M24	20 x M27
ISO 5211	F05	F05	F05	F05	F05	F05	F05	F07	F07	F10	F12	F12	F12	F14	F14	F14	F16
G	65	65	65	65	65	65	65	90	90	125	150	150	150	175	175	175	210
J	50	50	50	50	50	50	50	70	70	102	125	125	125	140	140	140	165
n x q	4 x 7	4 x 7	4 x 7	4 x 7	4 x 7	4 x 7	4 x 7	4 x 9	4 x 9	4 x 11	4 x 13	4 x 13	4 x 13	4 x 18	4 x 18	4 x 18	4 x 22
S	7	7	9	9	9	11	11	14	14	17	27	27	31.6	33.15	38	41.15	50.65
E	32	32	21	21	21	21	21	27	27	27	27	27	45	51.2	51.2	64.2	70.2

1: 请参考说明及建议 / 1: please see Instruction and Recommendations

重量 (kg) / Weight (kg)

DN	25	32	40	50	65	80	100	125	150	200	250	300	350	400	450	500	600
带手柄 / with lever	2,6	2,6	2,3	3,2	4,1	5,4	6,7	9,6	10,8	21,1	32,7	41,2	-	-	-	-	-

扭矩 (Nm) / Operating torque (Nm)

DN	25	32	40	50	65	80	100	125	150	200	250	300	350	400	450	500	600
DP bar																	
3	2,9	4,7	7,8	11,3	17	23	33	48	68	120	189	290	298	481	930	1250	2270
6	3,1	5,1	8,4	12	18	25	36	54	78	134	212	316	347	551	980	1350	2500
10	3,3	5,4	8,8	13	20	26	40	61	88	148	234	342	663	1050	1312	1848	3005
16	3,4	5,7	9,2	13	21	28	44	68	99	162	257	367	743	1235	1343	2112	3535

注意：请将扭矩数值乘以1.5倍作为选择驱动装置的依据。

N.B.: In order to choose the right actuator, we recommend multiplying the operating torque figure by a safety coefficient, K=1.5

最小管路直径 / Minimum pipe diameter Y

为确保碟板完全打开，请确保管路内径大于以下值

To ensure complete disc opening, make sure that the inner diameter of the pipe exceeds the following values

DN	25	32	40	50	65	80	100	125	150	200	250	300	350	400	450	500	600
	-	12	27	31	45	65	90	110	146	194	241	291	324	379	428	475	573

钻孔尺寸 / Drilling dimension

DN	法兰 / Flanges	25	32	40	50	65	80	100	125	150	200	250	300	350	400	450	500	600
F	PN10 EN1092	85	100	110	125	145	160	180	210	240	295	350	400	460	515	565	620	725
n° x M	PN10 EN1092	4 x M12	4 x M16	4 x M16	4 x M16	4 x M16	8 x M16	8 x M16	8 x M16	8 x M16	8 x M20	12 x M20	12 x M20	16 x M20	16 x M24	20 x M24	20 x M24	20 x M27
F	PN16 EN1092	85	100	110	125	145	160	180	210	240	295	355	410	470	525	585	650	770
n° x M	PN16 EN1092	4 x M12	4 x M16	4 x M16	4 x M16	4 x M16	8 x M16	8 x M16	8 x M16	8 x M16	8 x M20	12 x M24	12 x M24	16 x M24	16 x M27	20 x M27	20 x M30	20 x M33
F	ANSI B16.5 #150	-	-	98.6	120.7	139.7	152.4	190.5	215.9	241.5	298.5	362	431.8	-	-	-	-	-
n° x M	ANSI B16.5 #150	-	-	4 x M14	4 x M16	4 x M16	4 x M16	8 x M16	8 x M20	8 x M20	8 x M20	8 x M24	12 x M24	-	-	-	-	-

法兰表 / Flange chart

DN		25	32	40	50	65	80	100	125	150	200	250	300	350	400	450	500	600
安装在法兰中间时 / For mounting between flanges	PN10 EN1092	V	V	V	V	V	V	V	V	V	V	V	V	V	V	V	V	V
	PN16 EN1092	V	V	V	V	V	V	V	V	V	V	V	V	V	V	V	V	V
	ANSI B16.5 #150	-	-	V	V	V	V	V	V	V	V	V	V	-	-	-	-	-

推荐法兰 / Recommended flange types

标准 / Norms	型号 / Type	
EN 1092-1 PN6/10/16	Type 11	对焊法兰 / weld neck
	Type 21	整体法兰 / integral
	Type 02 + 35	对焊环板式松套管法兰 / loose plate with weld ring neck
	Type 02 + 36	翻边环板式松套钢制管法兰 / loose plate with pressed collar
	Type 04 + 34	对焊环带颈松套钢制管法兰 / loose plate with weld neck collar
ANSI B16.1#150° ANSI B16.5#150°		平面法兰 / flat face
		定面法兰 / raised face
		松套法兰 / lap joint

凸耳式蝶阀 / Lug butterfly valve

材质 / Materials

组件 Component	材质 / Material
1 阀体 Body	球铁 - Ductile iron EN GJS 400 - 15
2 蝶板 Disco	镀镍球铁 - Ductile iron nickel plated EN GJS 400 - 15 / 不锈钢 - Stainless steel ASTM A351 gr. CF8-M / 铝青铜 - Aluminium-bronze CuAl11Fe4 ASTM B148 C94500
3 阀杆 Stem	不锈钢 - Stainless Steel AISI 420
4 阀座 Liner	EPDM / NBR / FKM (Viton®) / PTFE
5 轴套 Bushing	PTFE
6 垫片 Washer	镀锌碳钢 Galvanized carbon steel
7 卡簧ISO3075 Circlip ISO3075	弹簧钢 Spring steel
8 O型圈 O-ring	FKM (Viton®)
9 手柄 Lever	DN25-150 铝-aluminium / DN200-250 球铁 - Ductile iron EN GJS 400-15
10 螺栓 Bolts	A2不锈钢 Stainless steel A2

最大工作压力 / Maximum pressure

介质* / Fluids*	安装位置 / Mounting	
	法兰中间 / BETWEEN FLANGES	管路末端 / END OF LINE
危险性气体 Hazardous gases	16 bar DN25-200 10 bar DN250-350 NO DN400-600	10 bar DN25-100 NO DN125-600
危险性液体 Hazardous liquids	16 bar DN25-400 10 bar DN450-600	10 bar DN25-400 6 bar DN450-600
非危险性气体 Non hazardous gases	16 bar DN25-300 10 bar DN350-500 6 bar DN600	10 bar DN25-300 6 bar DN350-500 4 bar DN600
非危险性液体 Non hazardous liquids	16 bar DN25-400 10 bar DN450-600	10 bar DN25-400 6 bar DN450-600
水** Water**	16 bar	16 bar

工作温度 / Temperature (°C)

温度 Temperature	最低 Min	最高 Max	
		长期 / continuous	短时 / peak
EPDM	-10	120	130
NBR	-10	80	90
FKM (Viton®)	-10	150	170
PTFE	-10	120	120

注意：温度上升时最大工作压力会有所下降；详情请参考压力温度曲线

NB: the maximum working pressure decreases while the temperature increases; please refer to "pressure/temperature" chart

* 危险性气体、液体的认证以2014/68/EU e 1272/2008 (CLP) 标准为准

** 是指供水和排水系统的水 (PED 2014/68/EU 112b)

* hazardous gas, liquids acc. 2014/68/EU e 1272/2008 (CLP)

** For supply, distribution and discharge of water (PED 2014/68/EU 112b)

压力温度曲线 / Pressure/temperature chart

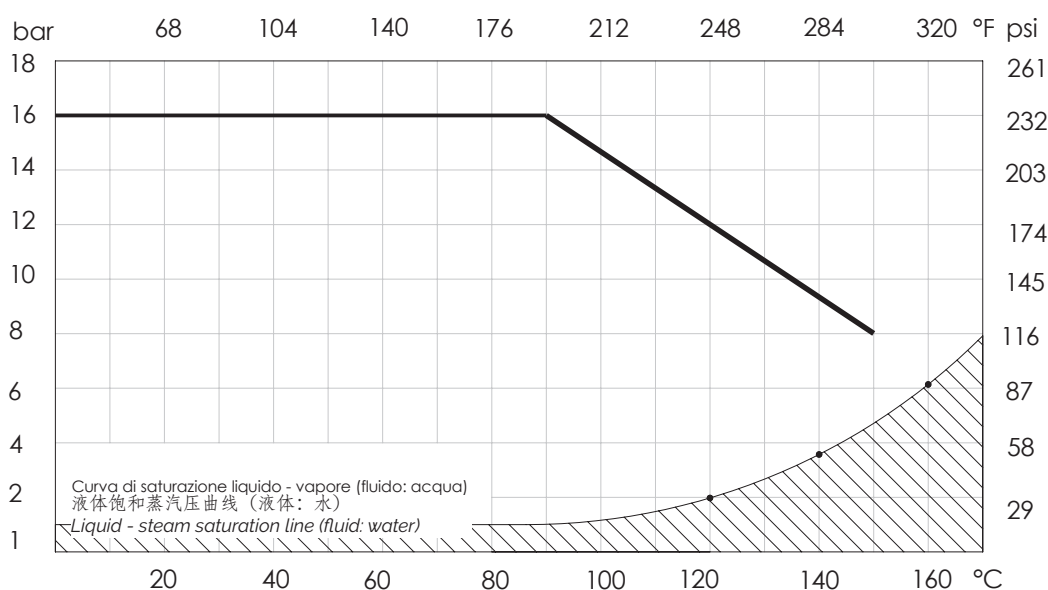

不适用于蒸汽系统。当工作温度和压力处于饱和蒸汽压曲线（阴影区域）下方时，请勿使用该阀门。

RANGE NOT SUITABLE FOR STEAM. DO NOT use when temperature and pressure are below the liquid-steam saturation line (hatched area)



水头损失 介质: 水 (1m H₂O = 0.098bar) - 阀门完全开启时的水头损失

Head loss Fluid: water (1m H₂O = 0.098bar) - Head loss with shutter fully opened

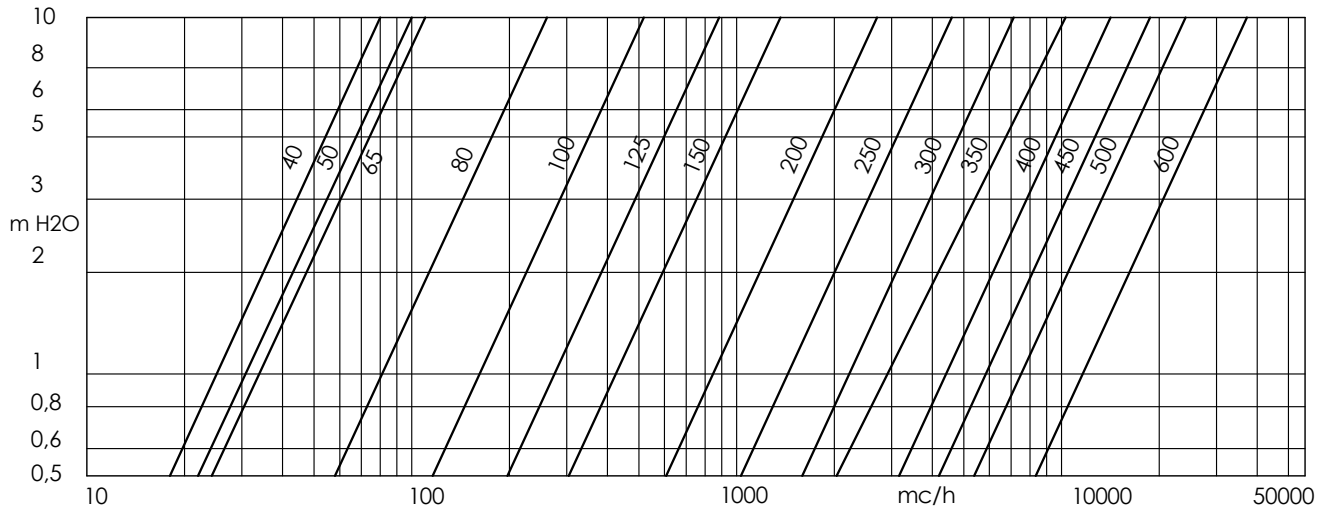

流通率/开启位置曲线 在相同水头损失情况下全开时的流通比率

Flow rate / opening position chart Flow percentage on the flow at full opening under the same loss of head.

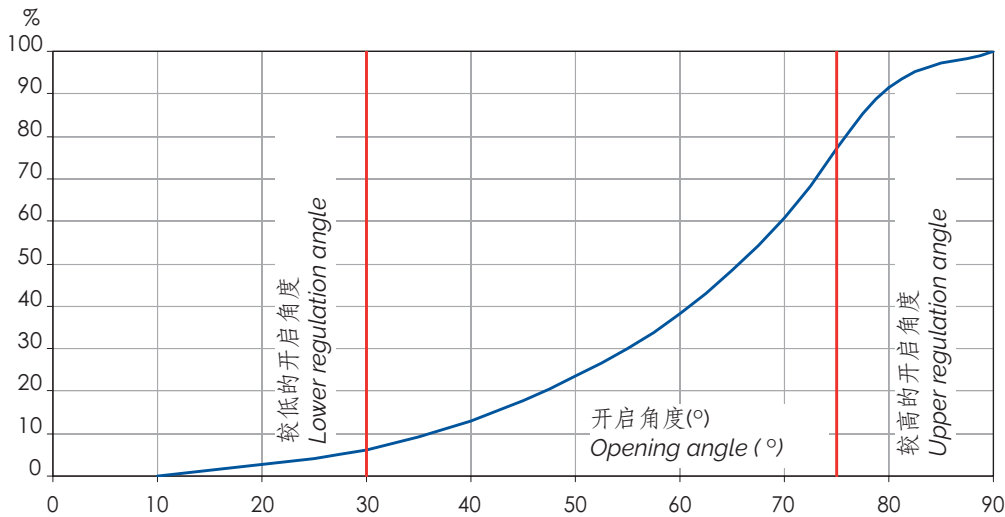

Kv - DN表 (m³/h, 当水头损失为1 bar时) / **Kv - DN chart** (mc/h per bar)

DN	mm	40	50	65	80	100	125	150	200	250	300	350	400	450	500	600
	ins	1" 1/2	2"	2" 1/2	3"	4"	5"	6"	8"	10"	12"	14"	16"	18"	20"	24"
10°		0.04	0.05	0.00	0.17	0.26	0.43	0.69	2.6	2.6	3.5	5.2	6.9	9.5	12	19
20°		2.1	2.6	3.8	7.8	15	25	39	52	130	202	292	401	531	683	1055
30°		4.8	6	14	16	31	53	82	142	276	427	617	849	1124	1445	2234
40°		10	13	33	34	67	115	177	250	599	926	1376	1839	2437	3133	4840
50°		19	23	53	60	120	205	316	450	1068	1650	2384	3279	4342	5609	8626
60°		30	38	75	100	199	339	522	713	1768	2730	3945	5425	7185	9238	14272
70°		48	60	98	158	314	535	827	1122	2798	4322	6243	8585	11371	14620	22587
80°		73	91	108	237	471	803	1241	1723	4196	6483	9364	12878	17057	21930	33882
90°		79	99	108	261	518	883	1364	2716	4611	7124	10291	14152	18743	24099	37232

螺栓长度计算方法

$$L_{max} \leq T+w+P$$

L max = 螺钉最大长度

P = 最大旋入深度

T = 法兰厚度 (客户)

w = 螺钉头处垫片厚度

H > L-T = 最小螺纹长度

BOLT LENGTH CALCULATION

$$L_{max} \leq T+w+P$$

L max = maximum length of screws

P = maximum implantation depth

T = flange thickness (customer)

w = thickness of washer at the screw head

H > L-T = minimum threaded length

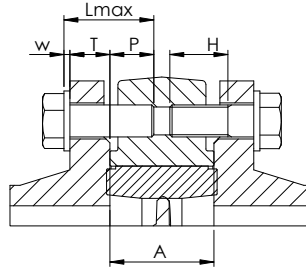

DN	25	32	40	50	65	80	100	125	150	200	250	300	350	400	450	500	600
A	33	33	33	43	46	46	52	56	56	60	68	78	78	102	114	127	154
P	14	14	14	18	20	20	22	22	25	27	30	34	34	38	38	42	45
w (DIN125/ISO7089)	2.5	3	3	3	3	3	3	3	3	3	4	4	4	4	4	4	5

例如，阀门安装在EN 1092-1 11型PN16和PN10钢制法兰之间时，并装有DIN125 / ISO7089垫片时，推荐的螺钉长度见下表。我们建议根据实际安装情况检查螺钉长度是否正确。

As an example, the recommended screw length are given in the following table provided the valve is installed between steel EN 1092-1 type 11 PN16 and PN10 flanges, and with DIN125/ISO7089 washers. We recommend checking for the correct screw length according to actual installation features.

DN	25	32	40	50	65	80	100	125	150	200	250	300	350	400	450	500	600
M X L	M12	M16	M16	M16	M16	M16	M16	M16	M20	M20	M24	M24	M24	M27	M27	M30	M33
PN16	x30	x30	x35	x35	x40	x40	x45	x45	x50	x50	x60	x60	x60	x70	x70	x80	x90
M X L	M12	M16	M16	M16	M16	M16	M16	M16	M20	M20	M20	M20	M20	M24	M24	M24	M27
PN10	x30	x30	x35	x35	x40	x40	x45	x45	x50	x50	x60	x60	x60	x70	x70	x70	x80

我们不提供螺栓 / We do not supply the bolting

Brandoni SpA保留随时更改产品设计和/或构造的权利，恕不另行通知。更多信息，请访问 www.brandonivalves.it

Brandoni SpA reserves the right to make changes in design and/or construction of the products at any time without prior notice. For further information, please refer to www.brandonivalves.it

J9 - L9系列说明及建议

安装与运输

- 请保存在密闭干燥的环境中。
- 储存时蝶板须处于半开状态（如图1所示）。
- 避免碰撞，手柄、手轮、齿轮箱、执行器等要加倍防护。
- 搬运或吊起阀门时，不要让手柄或手轮成为受力部位。

维护

此类阀门无需维护。

建议

阀门进行任何维修或拆卸前，请确保：管路、阀门和流体已冷却；压力已卸去；管路及管道中的有毒、易燃、有腐蚀性的流体已排净。

50°C以上及0°C以下的流体可能会对人体造成伤害。

安装

- 小心装卸。
- 不能在阀门与法兰连接后，再去将法兰管路焊接。
- 水锤作用会导致阀门损坏或破裂。倾斜、扭转、阀门管路中心线与管路未对准会使阀门受力。建议安装弹性头等来尽量减少管路的震荡。蝶板必须处于半开状态。（如图1所示）
- 阀杆顶部设有一个指示蝶板位置的凹槽（如图2所示），参照其指示位置，以将手柄或驱动器准确装回。
- 可通过阀轴水平安装或垂直安装阀门。因为流体中可能存在固体颗粒（如沙子、杂质等）沉积在蝶板底部使其不好开启。所以建议蝶阀水平安装（如图3所示）。

图1/FIG.1



图2/FIG.2



压力小于6 bar时，L9系列原则上允许安装在管路末端（阀门下游无管路）。对于末端安装：

- J9系列在所有压力下，L9系列在压力>6 bar时，必须安装对接法兰。

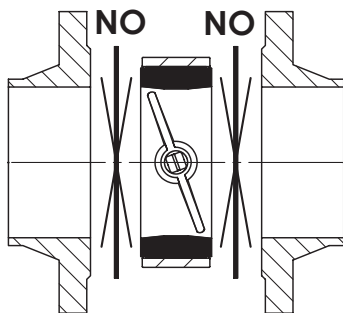
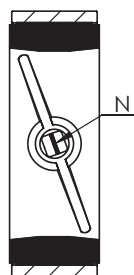
- L9系列在压力<6 bar时，也建议使用对接法兰。

请参照压力表，核实最大工作压力及使用限制条件。使用时注意不要超过最大工作压力。

请将阀门置于两个法兰中间，安装时确保有足够的空间而不损坏阀门橡胶。阀门与法兰之间无需安装垫片（如图1所示）。

Instruction and Recommendations for series J9 - L9

INSTALLATION AND TRANSPORT

- Keep in dry and closed place.
- While stored, the disc must be partially open (Fig. 1).
- Avoid knocks, take special care to protect lever, hand wheel, gear boxes/actuators.
- Do not use lever or hand wheel to lift the valve.

MAINTENANCE

The valve does not require maintenance.

Recommendations

Before carrying out maintenance or dismantling the valve, be sure that the pipes, valves and liquids have cooled down, that the pressure has decreased and that the lines and pipes have been drained in case of toxic, corrosive, inflammable or caustic liquids.

Temperatures above 50°C and below 0°C might cause damage to people.

INSTALLATION

- Handle with care.
- Do not weld the flanges to the piping after installing the valve.
- Water hammers might cause damage and ruptures. Inclination, twisting and misalignments of the piping may subject the valve to stress, once installed. It is recommended that elastic joints be used in order to reduce these effects as much as possible. The disc must be partially open (Fig. 1).

The stem has a machined notch N (Fig. 2), which indicates the position of the disc; consider this indication, in order to mount the levers and actuators correctly.

The mounting can be made with the stem axis in a horizontal or vertical position. In case the fluid contains suspended solid particles (for example, sand, impurities, etc.) or solid particles that may leave deposits, it is recommended that the valve be installed with its axis horizontal, and in such a way that the bottom end of the disc opens in the direction of flow, F. (Fig. 3)

图3/FIG.3

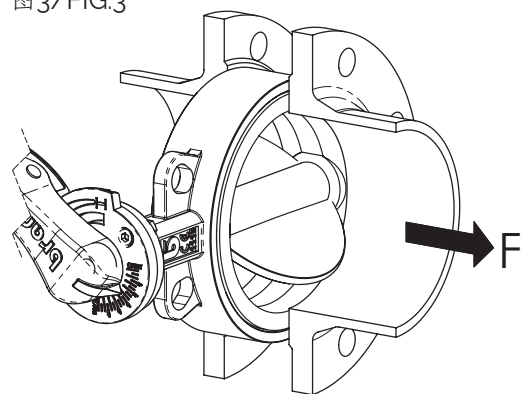

The item L9 allows the dismantling of the pipes downstream, for pressures below 6 bar. For end of line installation:

- series J9 (all pressures), series L9 (pressure > 6 bar): counter flange MUST be installed

- series L9 (pressure < 6 bar): it is recommended that a counter flange be installed.

Verify maximum working pressure and limits of use under section "maximum pressure".

Place the valve between two flanges. While placing the valve, ensure there is sufficient space in order not to damage the rubber. Do not mount seals between valve and flanges (Fig. 1).

仔细清洁连接表面，阀门安装时不要直接接触橡胶表面（如伸缩接头），蝶阀应与金属面相配合（如图4所示）。连接管路内径必须大于最小管路直径。不能在阀门与法兰连接好之后，再去将法兰与管路进行焊接。推荐使用表中建议的标准法兰。尽可能不用平焊法兰（EN 1902-1型）；如焊接法兰已使用，要确保法兰与阀门对正，焊接处良好，以防止突出或尖锐的地方损坏阀座（如图5所示）。

将蝶阀固定在中间位置。

交叉对称旋紧螺栓，以确保阀门与法兰连接后压力分布均衡。（如图6所示）

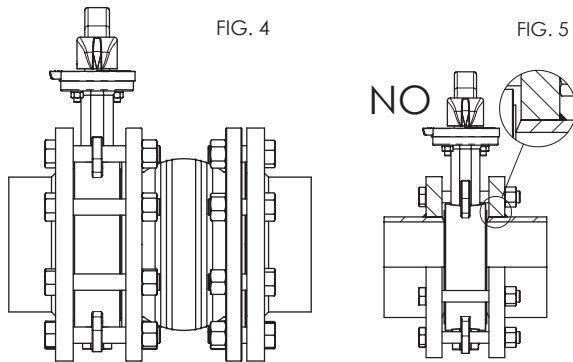

对于凸耳式蝶阀，请选用合适长度的螺栓，以保证将阀座橡胶完全压紧。

因流体扰动会加速阀门的磨损，降低其使用寿命，因此建议阀门的安装位置应保证：距离上游管件接头及弯头的距离至少为1倍DN（公称直径），距离下游管件接头及弯头的距离至少为2-3倍DN（公称直径）。

当阀门处于全开位置时，其所占空间要大于阀门的结构长。所以使用时需要验证阀门全开时，不会影响到与之临近的其它部件的正常使用或造成其损坏（如图7A所示）。

当出现此类问题时，可在蝶阀与其它部件之间安装一个间隔法兰以保证其正常工作（如图7B所示）。



图7A
FIG. 7A

Carefully clean the contact surface. Do not install the butterfly valve in direct contact with a rubber surface (for example, expansion joints); the best installation is when the rubber is in contact with metal (Fig. 4). In order to achieve correct working, the internal diameter of the pipe must be greater than the value indicated in the chart. Do not weld the flanges to the tube if the valve has already been installed. It is recommended that the flanges listed in the chart be used. As far as possible, avoid flat flanges for welding (EN 1092 01 type); if these flanges are used, ensure perfect centring between the flange and valve, and be sure to weld exactly edgewise to the flange. Do not let protrusions or sharp edges on the piping cause damage to the rubber surface of the valve (Fig. 5).

Centre the valve on holes while using wafer type valves.

Tighten the bolts crosswise and progressively, in order to distribute the pressure equally before the body and flanges come into contact with each other. (Fig. 6)

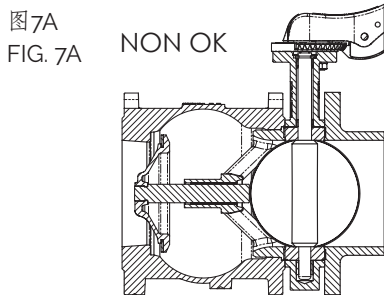
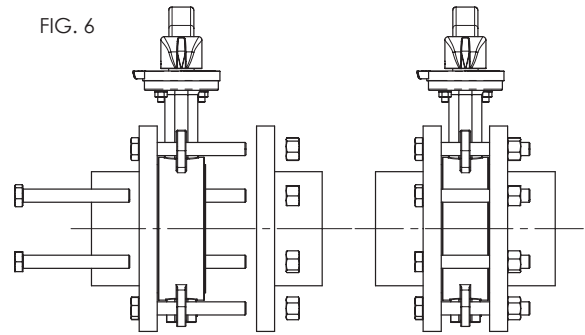

With regard to the Lug version, check that the screws are the correct length, in order to allow complete compression of the lining rubber.

Turbulences of the fluid might increase erosion and reduce the life-cycle of the valve. Install the valve at a distance of at least 1 x DN upstream, and at a distance of 2-3 x DN downstream, away from fittings or bends. In the open position, the valve is larger than the nominal Face to Face value.

Check that no other components of the piping interfere or create damage or malfunction (Fig. 7A).

If they do, a spacer should be inserted for the valve to operate correctly (Fig. 7B).



图7B
FIG. 7B

处置

对于输送危险介质（有毒、腐蚀性……）的阀门，如果阀门中可能残留残余物，请采取适当的安全预防措施并进行必要的清洁。负责人员必须经过培训并配备适当的防护装置。

在处置之前，请按照不同材料拆卸阀门并分离组件。请参考产品资料获取更多信息。根据当地和现行有效的法规并在考虑环境的情况下，将分类的物料送交回收利用（例如金属材料）或进行处置。

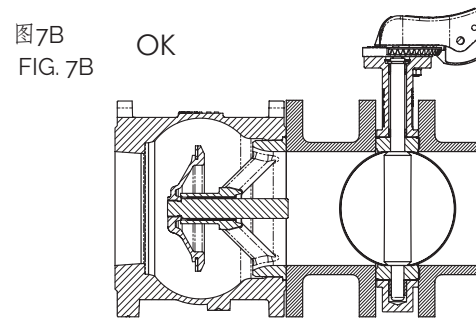
DISPOSAL

For valve operating with hazardous media (toxic, corrosive...), if there is a possibility of residue remaining in the valve, take due safety precaution and carry out required cleaning operation. Personnel in charge must be trained and equipped with appropriate protection devices.

Prior to disposal, disassemble the valve and separate the component according to various materials. Please refer to product literature for more information. Forward sorted material to recycling (e.g. metallic materials) or disposal, according to local and currently valid legislation and under consideration of the environment.