

# J9.000系列



GJL 250对夹式蝶阀  
*GJL 250 Wafer butterfly valve*

DOWNLOAD  
DATASHEET



**b**-Smart, Be-Brandoni



**brandoni**  
VALVES

[www.brandonivalves.com](http://www.brandonivalves.com)

## GJL 250对夹式蝶阀 / GJL 250 Wafer butterfly valve

J9系列对夹式蝶阀，带有中心式阀板和对夹式阀体，阀体材质为铸铁，严格按照相关产品质量标准生产，符合EN ISO 9001标准。

适用于供热、空调、供水、水处理系统以及工业、农业系统。

(请确保您的选择与适用范围一致)

**YES:** 可安装于管路中部，可频繁开启。上法兰符合ISO 5211标准。可以安装各种执行器和驱动器。

可以用于切断和调节流体。

**NO:** 不适用于蒸汽系统。

The shut-off wafer butterfly valves in Series J9 are equipped with a centred disc and wafer type body, and are made of cast iron, manufactured in accordance with severe product norms and in conformity to EN ISO 9001.

These valves are suitable for heating and conditioning (HVAC), water treatment and water distribution, industrial applications, agricultural purposes. (Please ensure the choice of the corresponding item)

**YES:** for in line installation with frequent actuation; the integrated support, in accordance with ISO 5211, allows easy mounting of a wide range of actuators and drives.

They are suitable for choking and regulating the flow.

**NO:** for steam.

### 附件

- 用于连接给水总管系统的阀杆延长装置
- 位置指示器和齿轮箱挂锁
- 齿轮箱限位开关
- 用来指示开关位置的限位开关

### 驱动器

- 气动执行器：单作用/双作用
- 可定制：限位开关，位置指示器
- 电动执行器
- 齿轮箱
- 链条驱动

### 认证 / Certifications



符合2014/68/UE (ex 97/23/CE PED) 标准

In conformity with directive 2014/68/UE (ex 97/23/CE PED)

#### 结构及检测标准:

结构长标准: EN558/1-20 (ISO 5752-20, DIN 3202K1)

法兰标准: EN1092, ANSI B16.5 #150

设计标准: EN593, EN12516, ISO 5211, EN12570

标识标准: EN19

检测标准: EN 12266 cat. A (ISO 5208 cat. A)

#### Norme costruttive e di collaudo (equivalenti):

Scartamento: EN558/1-20 (ISO 5752-20, DIN 3202K1)

Flange: EN1092, ANSI B16.5 #150

Design: EN593, EN12516, ISO 5211, EN12570

Marchatura: EN19

Collaudo: testate al 100% EN 12266 cat. A (ISO 5208 cat. A)

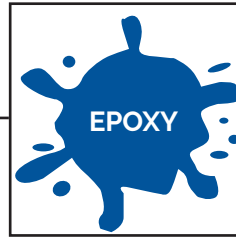

内外环氧树脂喷涂，耐高温。环保水性涂料。涂层厚度为150 μ。

*Inside and outside epoxy coating, high temperature resistant. Environmentally friendly, water-based paint. 150 μ thickness.*

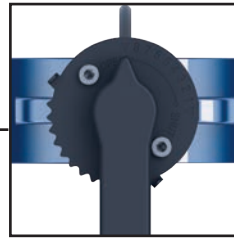
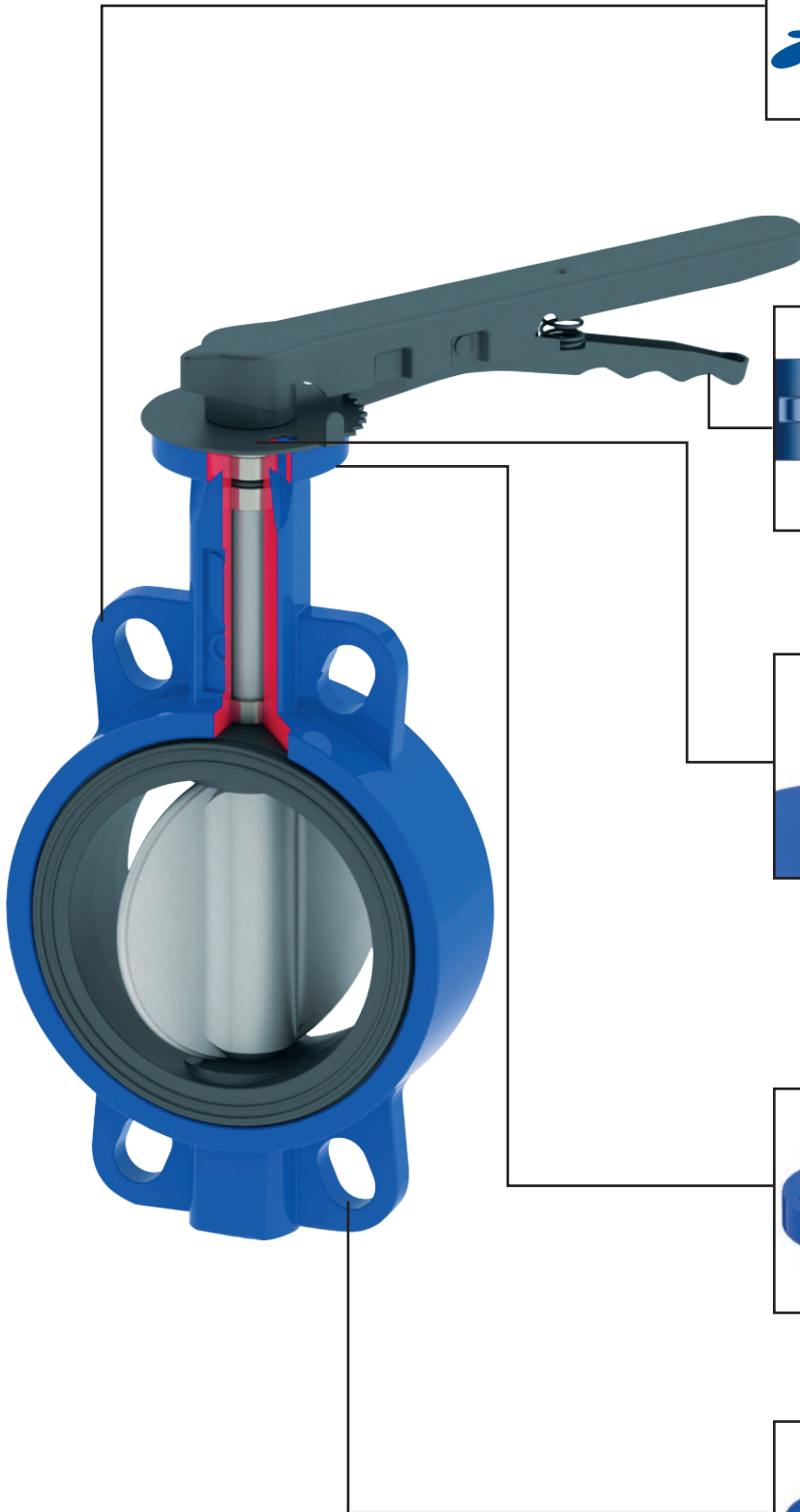

手柄可以锁定在任意刻度，利于调节流量。

*Lever suitable for intermediate regulation.*

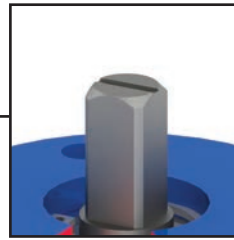

阀杆顶部设有一个指示蝶板位置的凹槽，确保手柄或驱动器移去后仍能准确判断阀门开合，以将手柄或驱动器准确装回。

*A notch machined at the top of the stem indicates the position of the disc and allows adjusting the lever/actuator to the correct position, when the command/lever is removed.*

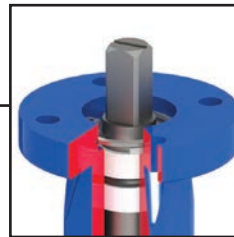

ISO 5211标准上法兰。

*Integrated ISO 5211 flange.*



连接孔可连接PN6、PN10、PN16及ANSI 150法兰。

*Alignment holes. Suitable for mounting between PN6, PN10, PN16 and ANSI 150.*

## GJL 250对夹式蝶阀 / GJL 250 Wafer butterfly valve

EPDM



### J9.000

阀体: EN GJL 250  
 阀板: 镀镍EN GJS400  
 阀座: EPDM  
 工作温度: -10 + 120 °C

Body: EN GJL 250  
 Disc: EN GJS400 nickel plated  
 Liner: EPDM  
 Temp: -10 a +120°C

## 驱动器和附件 / Actuators and accessories

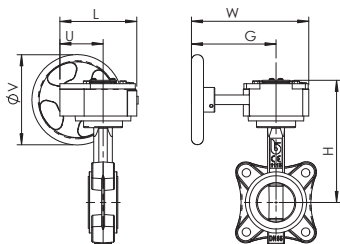

### J9 + RM

齿轮箱  
 Gear box

DN	25	32	40	50	65	80	100	125	150	200	250	300
J9 + RM	RM.0250	RM.0250	RM.0250	RM.0250	RM.0250	RM.0250	RM.0250	RM.0250	RM.0250	RM.0750	RM.1200	RM.1200
L	130	130	130	130	130	130	130	130	130	180	205	205
U	77	77	77	77	77	77	77	77	77	104	124	124
H	166	172	178	188	198	212	232	242	262	308	346	372
W	225	225	225	225	225	225	225	225	225	338	345	345
G	170	170	170	170	170	170	170	170	170	260	260	260
V	150	150	150	150	150	150	150	150	150	300	300	300
重量 / Weight Kg	5,7	5,7	5,8	6,1	6,4	7,02	8,12	9,61	11,11	22,3	32,8	42

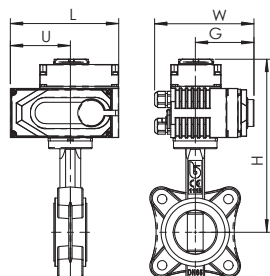

### J9 + AOX

电动执行器  
 Electric actuators

DN	25	32	40	50	65	80	100	125	150	200	250	300
J9 + AOX	003	003	003	003	005	005	008	010	015	030	060	060
L	123	123	123	123	160	160	160	189	189	268	268	268
U	74	74	74	74	89	89	89	107	107	152	152	152
H	217	223	229	239	257	271	291	309	329	394	430	456
W	100	100	100	100	121	121	121	145	145	225	225	225
G	65	65	65	65	84	84	84	89	89	119	119	119
重量 / Weight Kg	3,8	3,8	3,9	4,2	6	6,8	7,9	10,9	12,4	28,4	37,3	43,7

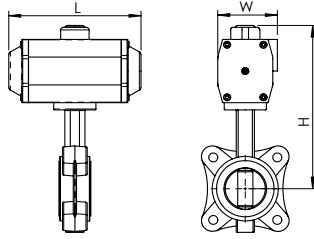

**Jg + AP**

气动执行器

Pneumatic actuator

DN	40	50	65	80	100	125	150	200	250	300
Jg + AP DE	AP2	AP2	AP3	AP3	AP3	AP3.5	AP4	AP4.5	AP5.5	AP5.5
L	155	155	213	213	213	236	276	310	388	388
H	219	229	256	270	290	310	345	402	472	498
W	73	73	85	85	85	98	110	128	160	160
重量 / Weight Kg	3.22	3.52	4.94	5.74	6.84	9.98	12.9	23.24	37.44	55.94
Jg + AP SE - 弹簧复位 / SPRING RETURN	AP3S	AP3S	AP3.5S	AP3.5S	AP4S	AP4.5S	AP5S	AP6S	AP8S	AP8S
L	213	213	236	236	276	310	366	468	563	563
H	236	246	316	330	365	412	445	520	646	672
W	85	85	98	98	110	128	140	175	215	215
重量 / Weight Kg	4.9	5.2	6.7	7.5	10.5	15.97	20.42	38.86	68.32	86.82

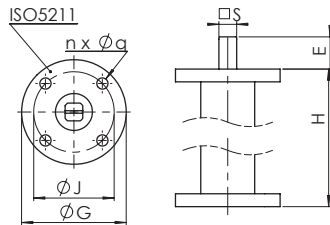

**KPROg**

用于连接给水总管系统的阀杆  
延长装置

Stem extension for water  
main system connection

DN	40-100	125-150	200	250-300
H	250-500-800-1000			
ISO 5211	F05	F07	F10	F12
G	65	90	125	150
J	50	F07	F10	F12
n x Ø q	4 x 7	4 x 9	4 x 11	4 x 13
E	20	26	26	26
S	11	14	17	27

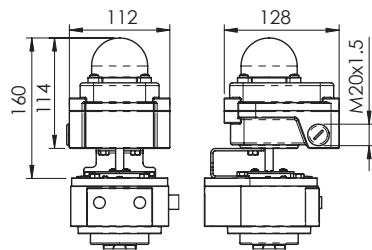
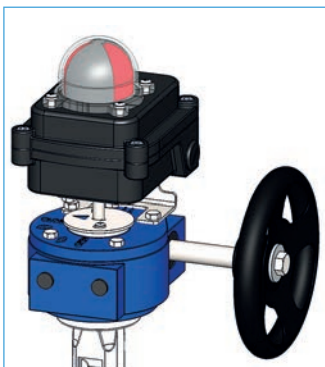

**KBOXRM**

齿轮箱限位开关

Limit switches box for gear  
box

标准机械开关  
可选：普通接近开关，防爆接近开关。

Mechanical switches per standard.  
Available on request: proximity switches,  
ATEX explosion proof proximity switches.

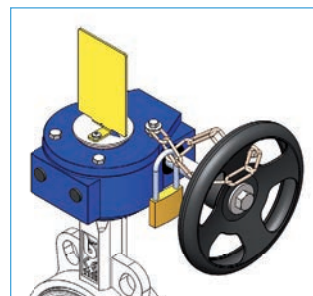

**KPOSRM**

位置指示器及齿轮箱挂锁

Position indicator and padlocking  
for gear box

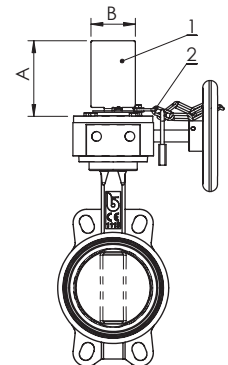

DN	25-150	200-400
A	100	120
B	60	80

1) 位置指示器  
2) 挂锁

1) Position indicator  
2) Chain for padlocking

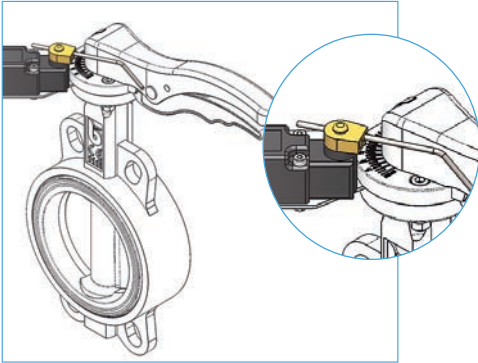

#### KFC109 - KFC209

用来指示开关位置的限位开关

Limit switches kit for ON-OFF indication

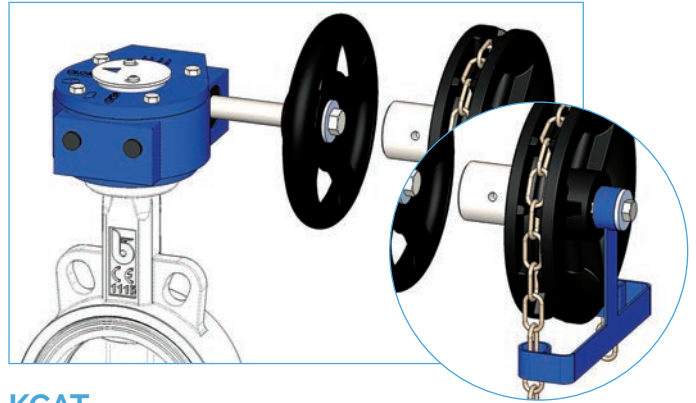

#### KCAT

链条驱动装置

Chain driver kit

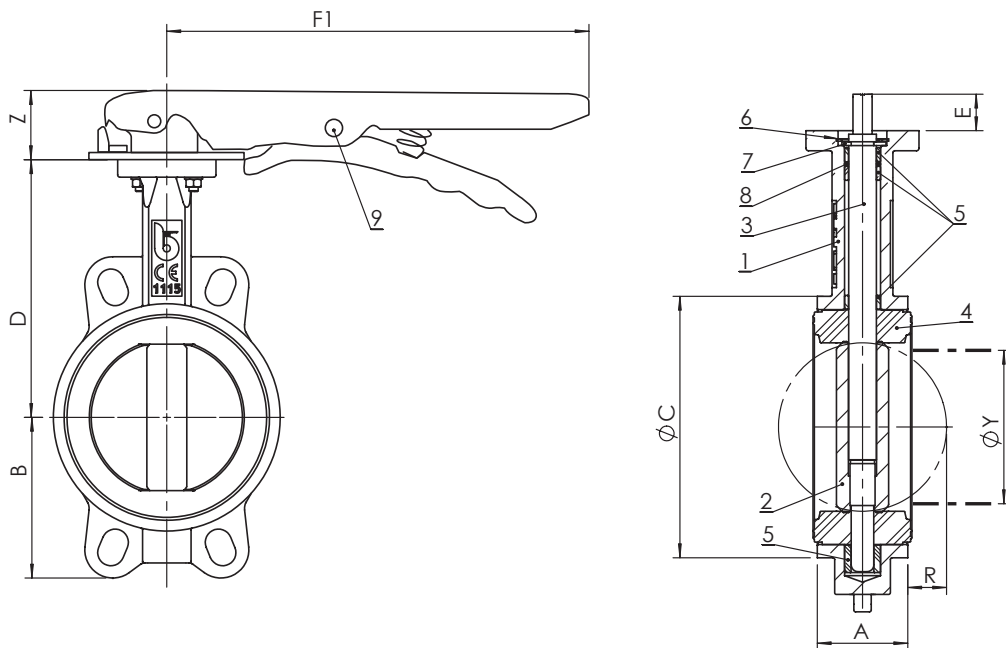

#### 尺寸 (mm) / Dimensions (mm)

DN	40	50	65	80	100	125	150	200	250	300
A	33	43	46	46	52	56	56	60	68	78
ØC	82	89	102	118	150	174	205	260	318	376
D	116	126	136	150	170	180	200	230	266	292
B	63	62	69	90	106	119	131	166	202	235
F1	193	193	193	216	216	250	250	350	375	-
Z	27	27	27	27	27	27	27	31	30	-
R	5	5	9	17	26	34	50	71	91	112
ØY 最小管路直径/min pipe	27	31	45	65	90	110	146	194	241	291

注意: DN 300将配备手动异径管

NOTE: DN 300 will be supplied with MANUAL REDUCER

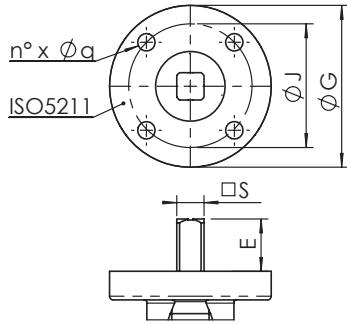

DN	40	50	65	80	100	125	150	200	250	300
ISO 5211	F05	F05	F05	F05	F05	F07	F07	F10	F12	F12
G	65	65	65	65	65	90	90	125	150	150
J	50	50	50	50	50	70	70	102	125	125
n x q	4 x 7	4 x 7	4 x 7	4 x 7	4 x 7	4 x 9	4 x 9	4 x 11	4 x 13	4 x 13
S	9	9	9	11	11	14	14	17	27	27
E	21	21	21	21	21	27	27	27	27	27

1: 请参考说明及建议 / 1: please see Instruction and Recommendations

### 重量 (kg) / Weight (kg)

DN	40	50	65	80	100	125	150	200	250	300
带手柄 - with lever	1,8	2,1	2,4	3,2	4,3	6,3	7,8	15,0	23,5	42

注意: DN 300将配备手动异径管

NOTE: DN 300 will be supplied with MANUAL REDUCER

### 扭矩 (Nm) / Operating torque (Nm)

DP bar										
3	7,8	11,3	17	23	33	48	68	120	189	290
6	8,4	12	18	25	36	54	78	134	212	316
10	8,8	13	20	26	40	61	88	148	234	342
16	9,2	13	21	28	44	68	99	162	257	367

注意: 请将扭矩数值乘以1.5倍作为选择驱动装置的依据。

N.B.: In order to choose the right actuator, we recommend multiplying the operating torque figure by a safety coefficient, K=1.5

### 最小管路直径 / Minimum pipe diameter Y

为确保碟板完全打开, 请确保管路内径大于以下值

To ensure complete disc opening, make sure that the inner diameter of the pipe exceeds the following values

DN	40	50	65	80	100	125	150	200	250	300
	27	31	45	65	90	110	146	194	241	291

### 法兰表 / Flange chart 安装在法兰中间时 / For mounting between flanges

	40	50	65	80(1)	100	125	150	200	250	300
PN6 EN1092	v (A)	v (A)	v (A)	v (D)	v (B)	v (A)	v (A)	v (A)	v (A)	v (A)
PN10 EN1092	v (A)	v (A)	v (A)	v (C)	v (A)	v (A)	v (A)	v (A)	v (A)	v (A)
PN16 EN1092	v (A)	v (A)	v (A)	v (C)	v (A)	v (A)	v (A)	v (A)	v (A)	v (A)
#150 ANSI B16.5	v (A)	v (A)	v (A)	v (D)	v (A)	v (A)	v (A)	v (A)	v (A)	v (A)

X: 不允许安装 / mounting not allowed

v: 允许安装 / mounting allowed

A, B, C, D: 螺栓布置图 / Bolt arrangement

(1): 对于带4孔的DN80 PN10-16, 参见螺栓布置图D / for DN80 PN10-16 with 4 holes see bolt arrangement D

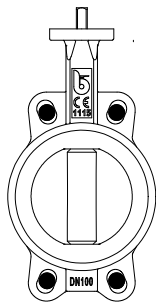

A

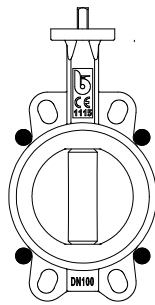

B

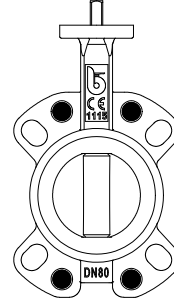

C

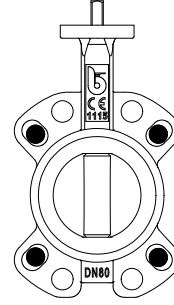

D

### 螺栓长度计算方法 / Bolt length calculation

螺栓长度计算方法 / Mounting with screws

用拉杆安装 / Mounting with tie-rods

$$L1 \geq A + 2T + w + N$$

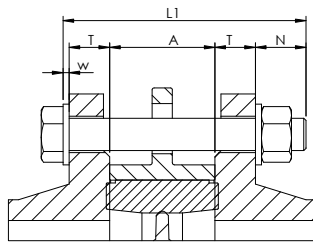

$$L2 \geq A + 2T + 2N$$

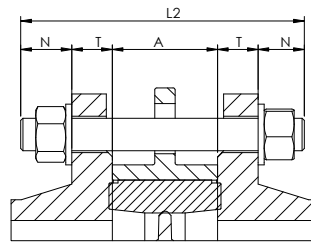

DN	40	50	65	80(1)	100	125	150	200	250	300
A	33	43	46	46	52	56	56	60	68	78
N*	24	24	24	24	24	26	26	26	32	32

T = 法兰厚度 (客户)

w = 螺钉头处垫片厚度

T = flange thickness (customer)

w = thickness of washer at the screw head

\* EN1092 PN6/10/16和ANSI 150, 以最大者为准 / Max among: EN1092 PN6/10/16 and ANSI 150.

\*\* 我们不提供螺栓 / We do not supply the bolting.

### 推荐法兰 / Recommended flange types

标准 / Norms	型号 / Type	
EN 1092-1 PN6/10/16	Type 11	对焊法兰 / weld neck
	Type 21	整体法兰 / integral
	Type 02 + 35	对焊环板式松套管法兰 / loose plate with weld ring neck
	Type 02 + 36	翻边环板式松套钢管法兰 / loose plate with pressed collar
	Type 04 + 34	对焊环带颈松套钢管法兰 / loose plate with weld neck collar
ANSI B16.1#150° ANSI B16.5#150°		平面法兰 / flat face
		定面法兰 / raised face
		松套法兰 / lap joint



## 材质 / Materials

组件 Component	材质 / Material
1 阀体 Body	EN GJL 250
2 蝶板 Disco	EN GJS 400 - 15 镀镍-nickel plated
3 阀杆 Stem	不锈钢 - Stainless Steel AISI 420
4 阀座 Liner	EPDM
5 轴套 Bushing	PTFE
6 垫片 Washer	镀锌碳钢 Galvanized carbon steel
7 卡簧ISO3075 Circlip ISO3075	弹簧钢 Spring steel
8 O型圈 O-ring	FKM (Viton®)
9 手柄 Lever	环氧涂层钢 Epoxy Steel
10 螺栓 Bolts	镀锌碳钢 Galvanized carbon steel

## 最大工作压力 / Maximum pressure

介质* / Fluids *	安装位置 / Mounting	
	法兰中间 / BETWEEN FLANGES	管路末端 / END OF LINE
危险性气体 Hazardous gases	NO	NO
危险性液体 Hazardous liquids	16 bar DN40-200 10bar DN250-300	10 bar DN40-200 6 bar DN250-300
非危险性气体 Non hazardous gases	16 bar DN40-125 10 bar DN150-300	10 bar DN40-125 6 bar DN150-300
非危险性液体 Non hazardous liquids	16 bar	10 bar
水** Water**	16 bar	16 bar

\* 危险性气体、液体的认证以2014/68/EU e 1272/2008 (CLP) 标准为准

\*\* 是指供水和排水系统的水 (PED 2014/68/EU 11.2b)

\* hazardous gas, liquids acc. 2014/68/EU e 1272/2008 (CLP)

\*\* For supply, distribution and discharge of water (PED 2014/68/EU 11.2b)

## 工作温度 / Temperature (°C)

温度 Temperature	最低 Min	最高 Max	
		长期 / continuous	短时 / peak
EPDM	-10	120	130

注意：温度上升时最大工作压力会有所下降；详情请参考压力温度曲线

NB: the maximum working pressure decreases while the temperature increases; please refer to "pressure/temperature" chart

## 压力温度曲线 / Pressure/temperature chart

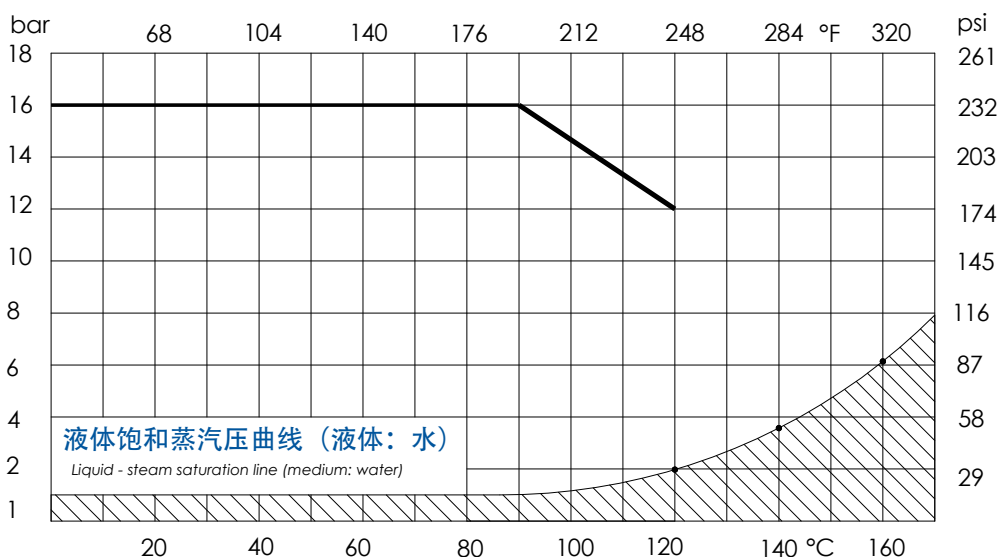

不适用于蒸汽系统。当工作温度和压力处于饱和蒸汽压曲线（阴影区域）下方时，请勿使用该阀门。

RANGE NOT SUITABLE FOR STEAM. DO NOT use when temperature and pressure are below the liquid-steam saturation line (hatched area)



### 水头损失 介质: 水 (1m H<sub>2</sub>O = 0,098bar) - 阀门完全开启时的水头损失

**Head loss** Fluid: water (1m H<sub>2</sub>O = 0,098bar) - Head loss with shutter fully opened

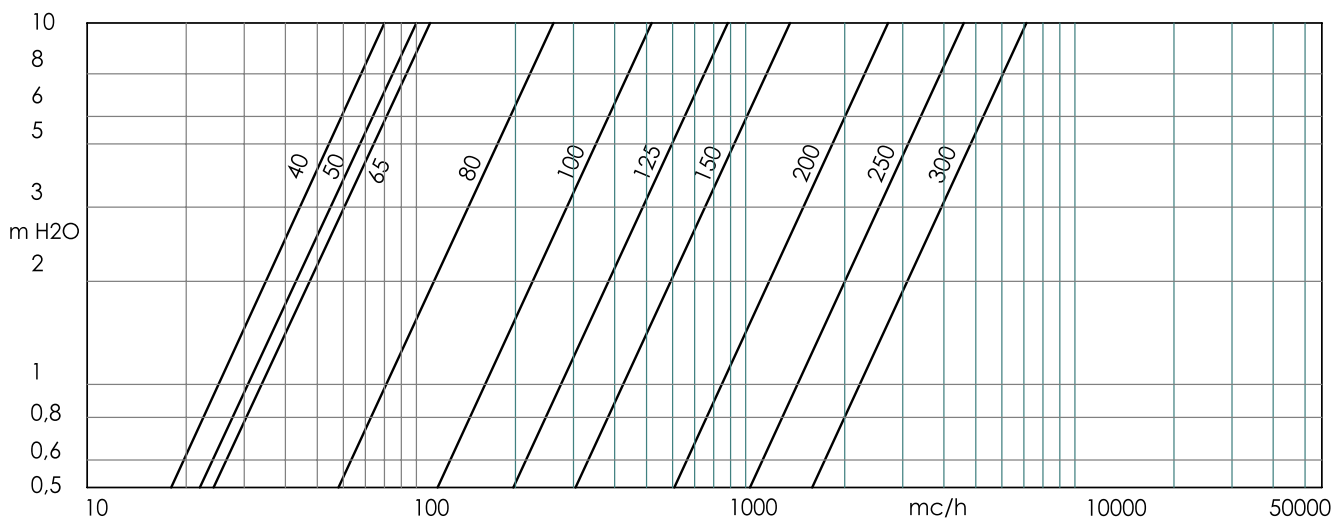

### 流通率/开启位置曲线 在相同水头损失情况下全开时的流通比率

**Flow rate / opening position chart** Flow percentage on the flow at full opening under the same loss of head.

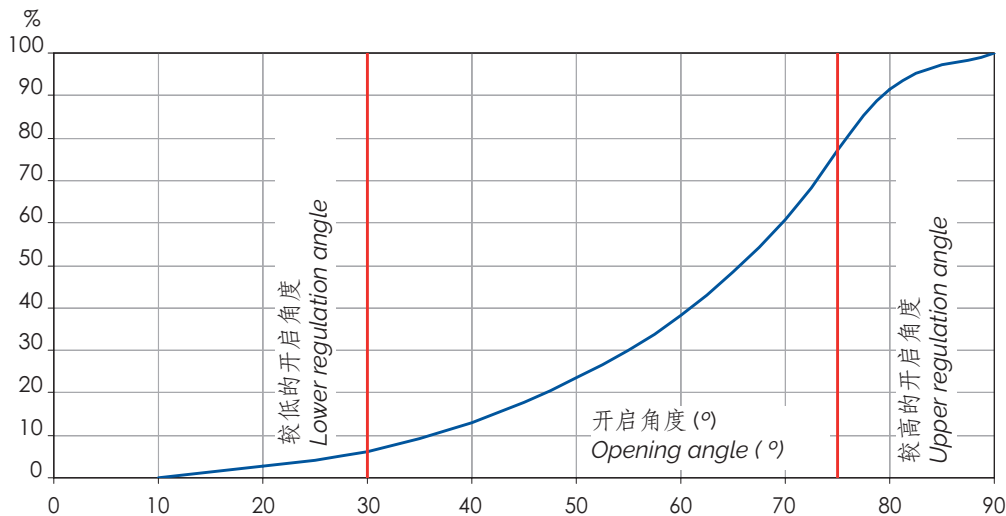

### Kv - DN表 (m<sup>3</sup>/h, 当水头损失为1bar时) / Kv - DN chart (mc/h per bar)

DN	mm	40	50	65	80	100	125	150	200	250	300
	ins	1" 1/2	2"	2" 1/2	3"	4"	5"	6"	8"	10"	12"
开启角度 OPENING ANGLE	10°	0,04	0,05	0,00	0,17	0,26	0,43	0,69	2,6	2,6	3,5
	20°	2,1	2,6	3,8	7,8	15	25	39	52	130	202
	30°	4,8	6	14	16	31	53	82	142	276	427
	40°	10	13	33	34	67	115	177	250	599	926
	50°	19	23	53	60	120	205	316	450	1068	1650
	60°	30	38	75	100	199	339	522	713	1768	2730
	70°	48	60	98	158	314	535	827	1122	2798	4322
	80°	73	91	108	237	471	803	1241	1723	4196	6483
	90°	79	99	108	261	518	883	1364	2716	4611	7124

## J9 - L9系列说明及建议

### 安装与运输

- 请保存在密闭干燥的环境中。
- 储存时蝶板须处于半开状态（如图1所示）。
- 避免碰撞，手柄、手轮、齿轮箱、执行器等要加倍防护。
- 搬运或吊起阀门时，不要让手柄或手轮成为受力部位。

### 维护

此类阀门无需维护。

### 建议

阀门进行任何维修或拆卸前，请确保：管路、阀门和流体已冷却；压力已卸去；管路及管道中的有毒、易燃、有腐蚀性的流体已排净。

50°C以上及0°C以下的流体可能会对人体造成伤害。

### 安装

- 小心装卸。
- 阀门安装时需保证其处于全开或全闭状态。
- 不能在阀门与法兰连接后，再去将法兰管路焊接。水锤作用会导致阀门损坏或破裂。倾斜、扭转、阀门管路中心线与管路未对准会使阀门受力。建议安装弹性头等来尽量减少管路的震荡。蝶板必须处于半开状态。（如图1所示）
- 阀杆顶部设有一个指示蝶板位置的凹槽（如图2所示），参照其指示位置，以将手柄或驱动器准确装回。
- 阀门可以水平安装，也可竖直安装。因为流体中可能存在因体颗粒（如沙子、杂质等）沉积在蝶板底部使其不好开启。所以建议蝶阀水平安装（如图3所示）。

图1/FIG.1



图2/FIG.2



图3/FIG.3

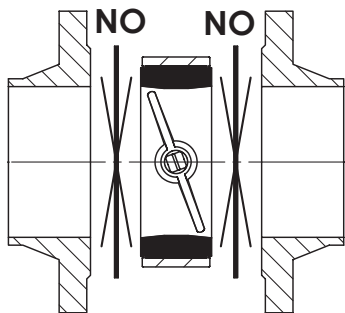

压力小于6 bar时，L9系列原则上允许安装在管路末端（阀门下游无管路）。对于末端安装：

- J9系列在所有压力下，必须安装对接法兰。

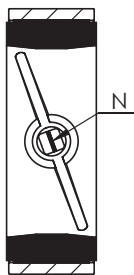
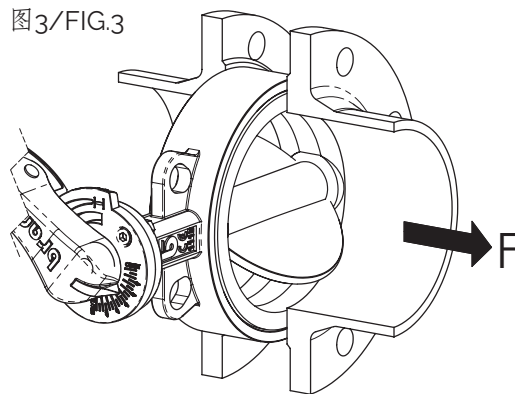
请参照压力表，核实最大工作压力及使用限制条件。使用时注意不要超过最大工作压力。

请将阀门置于两个法兰中间，安装时确保有足够的空间而不损坏阀门橡胶。阀门与法兰之间无需安装垫片（如图1所示）。仔细清洁连接表面，阀门安装时不要直接接触橡胶表面（如伸缩接头），蝶阀应与金属面相配合（如图4所示）。

## Instruction and Recommendations for series J9 - L9

### INSTALLATION AND TRANSPORT

- Keep in dry and closed place.
- While stored, the disc must be partially open (Fig. 1).
- Avoid knocks, take special care to protect lever, hand wheel, gear boxes/actuators.
- Do not use lever or hand wheel to lift the valve.

### MAINTENANCE

The valve does not require maintenance.

### Recommendations

Before carrying out maintenance or dismantling the valve, be sure that the pipes, valves and liquids have cooled down, that the pressure has decreased and that the lines and pipes have been drained in case of toxic, corrosive, inflammable or caustic liquids.

Temperatures above 50°C and below 0°C might cause damage to people.

### INSTALLATION

- Handle with care.
- Do not weld the flanges to the piping after installing the valve.
- Water hammers might cause damage and ruptures. Inclination, twisting and misalignments of the piping may subject the valve to stress, once installed. It is recommended that elastic joints be used in order to reduce these effects as much as possible. The disc must be partially open (Fig. 1).
- The stem has a machined notch N (Fig. 2), which indicates the position of the disc; consider this indication, in order to mount the levers and actuators correctly.
- The mounting can be made with the stem axis in a horizontal or vertical position. In case the fluid contains suspended solid particles (for example, sand, impurities, etc.) or solid particles that may leave deposits, it is recommended that the valve be installed with its axis horizontal, and in such a way that the bottom end of the disc opens in the direction of flow, F. (Fig. 3)

The item L9 allows the dismantling of the pipes downstream, for pressures below 6 bar. For end of line installation:

- series J9 (all pressures): counter flange **MUST** be installed. Verify maximum working pressure and limits of use under section "maximum pressure".

Place the valve between two flanges. While placing the valve, ensure there is sufficient space in order not to damage the rubber. Do not mount seals between valve and flanges (Fig. 1). Carefully clean the contact surface. Do not install the butterfly valve in direct contact with a rubber surface (for example, expansion joints); the best installation is when the rubber is in contact with metal (Fig. 4).

## GJL 250对夹式蝶阀 / GJL 250 Wafer butterfly valve

连接管路内径必须大于最小管路直径。不能在阀门与法兰连接好之后，再去将法兰与管路进行焊接。推荐使用建议的标准法兰。尽可能不用平焊法兰（EN1092-1型）；如焊接法兰已使用，要确保法兰与阀门对正，焊接处良好，以防止突出或尖锐的地方损坏阀座（如图5所示）。

将蝶阀固定在中间位置。

交叉对称旋紧螺栓，以确保阀门与法兰连接后压力分布均衡。（如图6所示）

In order to achieve correct working, the internal diameter of the pipe must be greater than the value indicated in the chart. Do not weld the flanges to the tube if the valve has already been installed. It is recommended that the flanges listed in the chart be used. As far as possible, avoid flat flanges for welding (EN 1092 01 type); if these flanges are used, ensure perfect centring between the flange and valve, and be sure to weld exactly edgewise to the flange. Do not let protrusions or sharp edges on the piping cause damage to the rubber surface of the valve (Fig. 5).

Centre the valve on holes while using wafer type valves.

Tighten the bolts crosswise and progressively, in order to distribute the pressure equally before the body and flanges come into contact with each other. (Fig. 6)

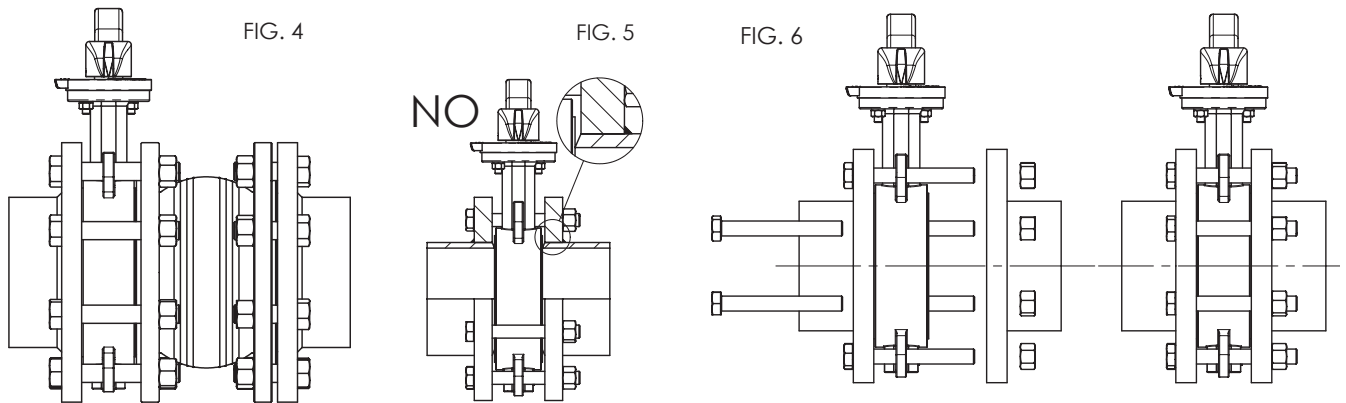

对于凸耳式蝶阀，请选用合适长度的螺栓，以保证将阀座橡胶完全压紧。

因流体扰动会加速阀门的磨损，降低其使用寿命，因此建议阀门的安装位置应保证：距离上游管件接头及弯头的距离至少为1倍DN（公称直径），距离下游管件接头及弯头的距离至少为2-3倍DN（公称直径）。当阀门处于全开位置时，其所占空间要大于阀门的结构长。

所以使用时需要验证阀门全开时，不会影响到与之临近的其它部件的正常使用或造成其损坏（如图7A所示）。

当出现此类问题时，可在蝶阀与其它部件之间安装一个间隔法兰以保证其正常工作（如图7B所示）。

With regard to the Lug version, check that the screws are the correct length, in order to allow complete compression of the lining rubber.

Turbulences of the fluid might increase erosion and reduce the life-cycle of the valve. Install the valve at a distance of at least 1 x DN upstream, and at a distance of 2-3 x DN downstream, away from fittings or bends. In the open position, the valve is larger than the nominal Face to Face value.

Check that no other components of the piping interfere or create damage or malfunction (Fig. 7A).

If they do, a spacer should be inserted for the valve to operate correctly (Fig. 7B).

