

# Serie 03-04 inox

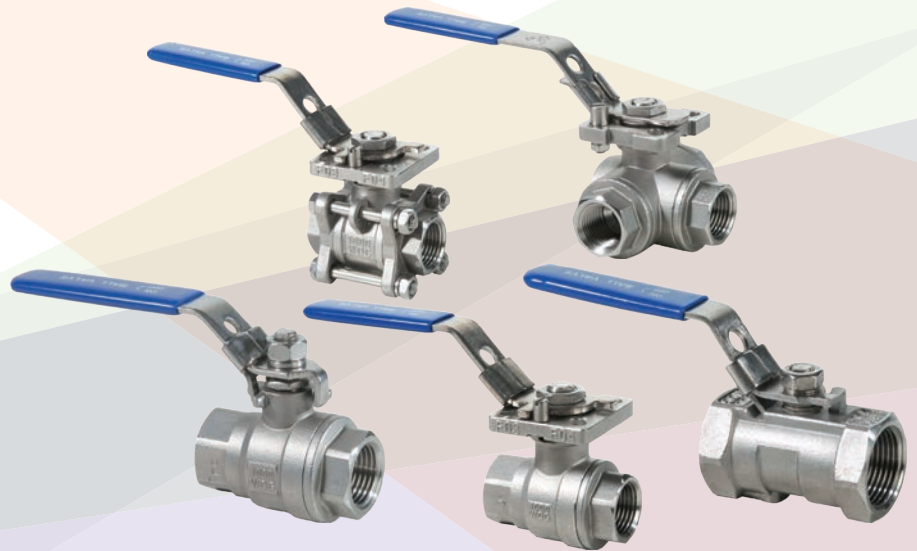

Valvola a sfera filettata in acciaio AISI 316 F/F  
*AISI 316 F/F threaded end ball valves*

DOWNLOAD  
DATASHEET



**b**-Smart, Be-Brandoni



**brandoni**  
VALVES

[www.brandonivalves.com](http://www.brandonivalves.com)

## Valvola a sfera filettata in acciaio AISI 316 F/F / AISI 316 F/F threaded end ball valves

Comprende valvole di intercettazione a sfera e due e tre vie filettate con corpo in AISI 316 e sfera flottante, realizzate in accordo alle normative di prodotto rilevanti. Disponibile nelle versioni:

**A3.622** > a due vie in 1 pezzo a passaggio ridotto

**B3.622** > a due vie in 2 pezzi a passaggio pieno, con e senza flangia ISO 5211

**C3.622** > a due vie in 3 pezzi a passaggio pieno, con flangia ISO 5211

**04.622** > a tre vie con sfera a "L" o "T", con flangia ISO 5211  
Sono adatte per impianti chimici e industriali, per riscaldamento e condizionamento (HVAC), teleriscaldamento, applicazioni agricole, oli e idrocarburi.

(Fatta salva la scelta corretta dell'articolo in base all'applicazione)

**Sono idonee:** per servizio che richieda frequenti azionamenti; possono essere equipaggiate con servocomandi manuali, elettrici e pneumatici.

**Non sono idonee:** per vapore, per la parzializzazione e regolazione della portata.

### Comandi

- Attuatori pneumatici a doppio e semplice effetto
- Attuatori elettrici
- Riduttori manuali

This series consists of two and three way, threaded-end shut-off valves, with the body in AISI 316 and a floating ball, manufactured in accordance with the most severe product standards.

They are available in the following versions:

**A3.622** > two-way, 1 piece, reduced bore (NB no ISO flange)

**B3.622** > two-way, 2 pieces body, full bore, with or without ISO 5211 flange

**C3.622** > two-way, 3 pieces body, full bore, with or without ISO 5211 flange

**04.622** > three-way, with ball "L" shape or "T" shape, with ISO 5211 flange

Suitable for chemical and industrial plants, for heating and conditioning (HVAC), district heating, agricultural applications, oils and hydrocarbons. (Please ensure the choice of the corresponding item)

**YES:** for services with frequent actuation; suitable for installing of manual, electric and pneumatic servo commands.

**NO:** for steam, for choking and regulation of the flow.

### Actuators

- Double acting and single acting pneumatic actuators
- Electric actuators
- Gear box

### Certificazioni / Certifications



Conformi alla Direttiva 2014/68/EU (ex 97/23/CE PED)  
Conformi al D.M. 174 (direttiva 98/83/CE), per utilizzo a contatto con acqua potabile.

In conformity with directive 2014/68/UE (ex 97/23/CE PED)  
Suitable for drinking water application, comply with Italian regulation D.M.174

### Norme costruttive e di collaudo (equivalenti):

Filetti: ISO7-1

Design: EN12516, ISO 5211

Collaudo: EN 12266 cat. A (ISO 5208 cat. A)

### Design and testing standards (correspondences):

Threading: ISO7-1

Design: EN12516, ISO 5211

Testing: EN 12266 cat. A (ISO 5208 cat. A)

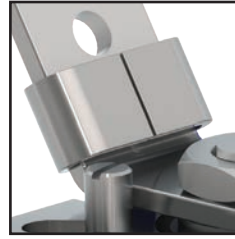
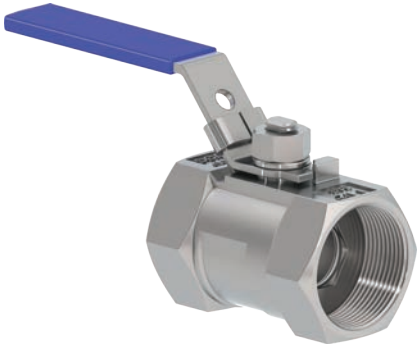

Bloccaggio in posizione (contro spostamenti accidentali) e lucchettabili.

*Lockable position (against accidental actuation) and padlocking.*



Flangia in accordo a ISO 5211 integrata.

*Integrated ISO 5211 flange.*

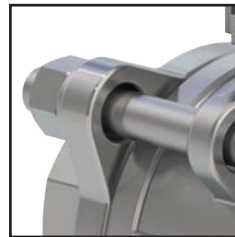

C3.622: facile smontaggio.

*C3.622: easy dismantling.*



04.622 sfera forata a T ad L.

Indicatore della direzione del flusso.  
4 sedi in PTFE garantiscono migliore stabilità alla sfera.

*04.622 ball drilled with T or L pattern bore.*

*Stem marking to show flow direction (connected port).*

*4 R-PTFE seat assure best ball stability*

Valvola a sfera filettata in acciaio AISI 316 F/F / AISI 316 F/F threaded end ball valves

## A passaggio ridotto Reduced bore



### A3.622

Corpo: Acciaio inox  
Sfera: Acciaio inox  
Asta: Acciaio inox  
Temp: da -25 a +180 °C

Body: Stainless steel  
Ball: Stainless steel  
Stem: Stainless steel  
Temp: -25 +180 °C

## A passaggio totale in due pezzi Full bore 2 pieces body



### B3.622

Corpo: Acciaio inox  
Sfera: Acciaio inox  
Asta: Acciaio inox  
Temp: da -25 a +180 °C

Body: Stainless steel  
Ball: Stainless steel  
Stem: Stainless steel  
Temp: -25 +180 °C



### B3.622 ISO

Corpo: Acciaio inox  
Sfera: Acciaio inox  
Asta: Acciaio inox  
Con flangia ISO 5211  
Temp: da -25 a +180 °C

Body: Stainless steel  
Ball: Stainless steel  
Stem: Stainless steel  
With ISO 5211 flange  
Temp: -25 +180 °C

## A passaggio totale in tre pezzi Full bore 3 pieces body



### C3.622 ISO

Corpo: Acciaio inox  
Sfera: Acciaio inox  
Asta: Acciaio inox  
Con flangia ISO 5211  
Temp: da -25 a +180 °C

Body: Stainless steel  
Ball: Stainless steel  
Stem: Stainless steel  
With ISO 5211 flange  
Temp: -25 +180 °C

## A tre vie a passaggio ridotto Three-way reduced bore



### T4.622 ISO

Corpo: Acciaio inox  
Sfera: Acciaio inox foro a "T"  
Asta: Acciaio inox  
Con flangia ISO 5211  
Temp: da -25 a +180 °C

Body: Stainless steel  
Ball: Stainless steel "T" shape  
Stem: Stainless steel  
With ISO 5211 flange  
Temp: -25 +180 °C



### L4.622 ISO

Corpo: Acciaio inox  
Sfera: Acciaio inox foro a "L"  
Asta: Acciaio inox  
Con flangia ISO 5211  
Temp: da -25 a +180 °C

Body: Stainless steel  
Ball: Stainless steel "L" shape  
Stem: Stainless steel  
With ISO 5211 flange  
Temp: -25 +180 °C



**B3.622 + RM**  
Riduttore manuale  
Gear box

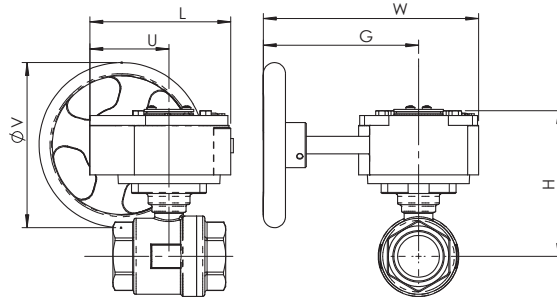

DN	1/4"	3/8"	1/2"	3/4"	1"	1" 1/4	1" 1/2	2"	2" 1/2	3"	4"
<b>B3.622 + RM</b>	RM.0250	RM.0250	RM.0250	RM.0250	RM.0250	RM.0250	RM.0250	RM.0250	RM.0250	RM.0250	RM.0250
<b>L</b>	130	130	130	130	130	130	130	130	130	130	130
<b>U</b>	77	77	77	77	77	77	77	77	77	77	77
<b>H</b>	139	139	139	144.5	107.5	116	121.5	129.5	155	171	183
<b>W</b>	225	225	225	225	225	225	225	225	225	225	225
<b>G</b>	170	170	170	170	170	170	170	170	170	170	170
<b>V</b>	150	150	150	150	150	150	150	150	150	150	150
<b>Peso / Weight Kg</b>	4,67	4,65	4,67	4,79	5,04	5,48	6,24	7,2	10,07	12,75	19,9



**C3.622 + RM**  
Riduttore manuale  
Gear box

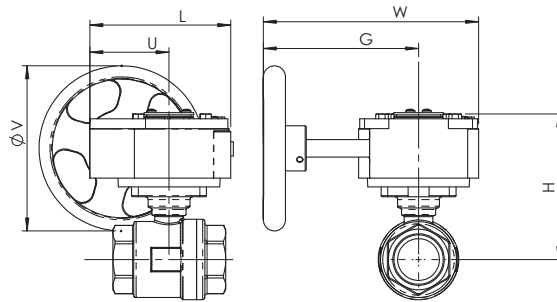

DN	1/4"	3/8"	1/2"	3/4"	1"	1" 1/4	1" 1/2	2"	2" 1/2	3"	4"
<b>C3.622 + RM</b>	RM.0250	RM.0250	RM.0250	RM.0250	RM.0250	RM.0250	RM.0250	RM.0250	RM.0250	RM.0250	RM.0250
<b>L</b>	130	130	130	130	130	130	130	130	130	130	130
<b>U</b>	77	77	77	77	77	77	77	77	77	77	77
<b>H</b>	134.5	134.5	139	104	107.5	116	121.5	130	162	174.5	187.5
<b>W</b>	225	225	225	225	225	225	225	225	225	225	225
<b>G</b>	170	170	170	170	170	170	170	170	170	170	170
<b>V</b>	150	150	150	150	150	150	150	150	150	150	150
<b>Peso / Weight Kg</b>	4,71	4,7	4,75	5,16	5,52	6,18	7,08	7,86	11,5	16,4	24,2



**T4.622/L4.622 + RM**  
Riduttore manuale  
Gear box

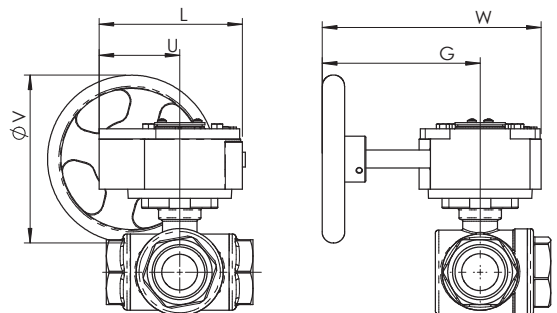

DN	1/4"	3/8"	1/2"	3/4"	1"	1" 1/4	1" 1/2	2"
<b>T4/L4.622 + RM</b>	RM.0250	RM.0250	RM.0250	RM.0250	RM.0250	RM.0250	RM.0250	RM.0250
<b>L</b>	130	130	130	130	130	130	130	130
<b>U</b>	77	77	77	77	77	77	77	77
<b>H</b>	139	139	139	103	109	118	122	133
<b>W</b>	225	225	225	225	225	225	225	225
<b>G</b>	170	170	170	170	170	170	170	170
<b>V</b>	150	150	150	150	150	150	150	150
<b>Peso / Weight Kg</b>	5	4,97	4,93	5,24	5,69	7,21	7,96	10,61

### Comandi e accessori / Actuators and accessories



#### B3.622 + AOX

Attuatori elettrici  
Electric Actuators

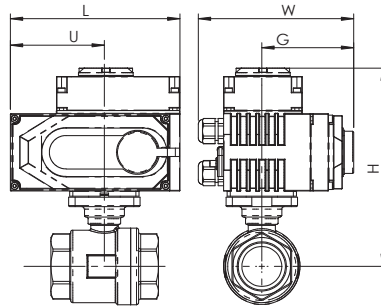

DN	1/4"	3/8"	1/2"	3/4"	1"	1" 1/4	1" 1/2	2"	2" 1/2	3"	4"
B3.622 + AOX	003	003	003	003	003	005	005	005	008	015	020
L	123	123	123	123	123	123	160	160	160	189	268
H	150	150	150	156	159	167	181	189	214	238	285
W	100	100	100	100	100	100	121	121	121	145	225
Peso Weight Kg	2,33	2,33	2,34	2,55	2,75	3,15	5,3	6,21	8,61	12,21	27,75



#### C3.622 + AOX

Attuatori elettrici  
Electric Actuators

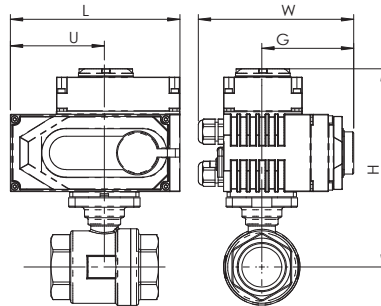

DN	1/4"	3/8"	1/2"	3/4"	1"	1" 1/4	1" 1/2	2"	2" 1/2	3"	4"
C3.622 + AOX	003	003	003	003	003	005	005	005	008	015	020
L	142	142	142	142	142	155	213	213	236	276	310
H	124	124	124	130	133	157	180	188	223	254	293
W	60	60	60	60	60	73	85	85	98	110	128
Peso Weight Kg	2,51	2,51	2,55	2,96	2,96	5,48	6,38	7,16	10,8	16,7	32,9



#### T4.622/L4.622 + AOX

Attuatori elettrici  
Electric Actuators

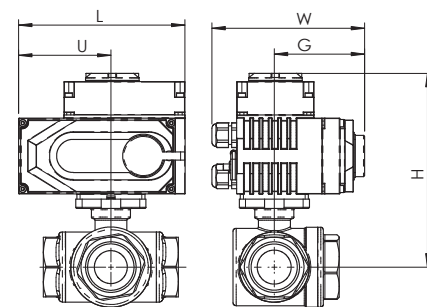

DN	1/4"	3/8"	1/2"	3/4"	1"	1" 1/4	1" 1/2	2"
04.622 + AOX	003	003	003	003	003	005	005	008
L	123	123	123	123	123	160	160	160
H	150	150	150	154	160	177	181	192
W	100	100	100	100	100	121	121	121
Peso Weight Kg	2,8	2,77	2,73	3,04	3,49	6,51	7,26	9,91

## Comandi e accessori / Actuators and accessories



### B3.622 + AP

Attuatori pneumatici  
Pneumatic actuator

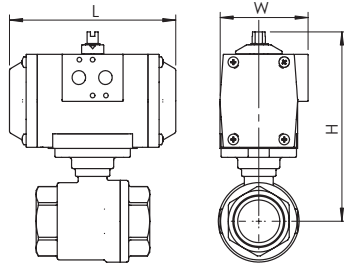

DN	1/4"	3/8"	1/2"	3/4"	1"	1" 1/4"	1" 1/2"	2"	2" 1/2"	3"	4"
<b>B3.622 + AP DE - DA</b>	AP1	AP1	AP1	AP1	AP1	AP2	AP3	AP3	AP3.5	AP4	AP4.5
L	142	142	142	142	142	155	213	213	236	276	310
H	124	124	124	130	133	157	180	188	223	254	293
W	60	60	60	60	60	73	85	85	98	110	128
<b>Peso Weight Kg</b>	1.23	1.23	1.24	1.45	2.07	2.47	4.24	5.15	8.69	12.71	22.99
<b>B3.622 + AP SE - SPRING RETURN</b>	AP2S	AP2S	AP2S	AP2S	AP3S	AP3S	AP3.5S	AP4S	AP4.5S	AP5S	AP5.5S
L	155	155	155	155	213	213	236	276	310	366	388
H	140	140	140	146	166	174	190	213	265	294	387
W	73	73	73	73	85	85	98	110	128	140	160
<b>Peso Weight Kg</b>	1.79	1.79	1.8	2.01	3.75	4.15	6	8.81	14.68	20.23	31.84



### C3.622 + AP

Attuatori pneumatici  
Pneumatic actuator

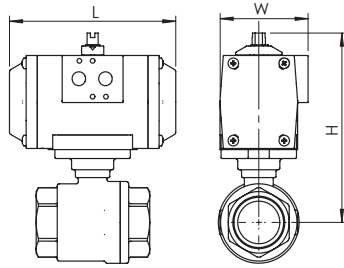

DN	1/4"	3/8"	1/2"	3/4"	1"	1" 1/4"	1" 1/2"	2"	2" 1/2"	3"	4"
<b>C3.622 + AP DE - DA</b>	AP1	AP1	AP1	AP1	AP1	AP3	AP3	AP3	AP3.5	AP4	AP4.5
L	142	142	142	142	142	155	213	213	236	276	310
H	124	124	124	130	133	157	180	188	223	254	293
W	60	60	60	60	60	73	85	85	98	110	128
<b>Peso Weight Kg</b>	1.41	1.41	1.45	2.28	2.28	4.42	5.32	6.1	10.88	17.2	28.14
<b>C3.622 + AP SE - SPRING RETURN</b>	AP2S	AP2S	AP2S	AP2S	AP3S	AP3S	AP3.5S	AP4S	AP4.5S	AP5S	AP5.5S
L	155	155	155	155	213	213	236	276	310	366	388
H	176	176	180	145	166	174	190	213	272	298	392
W	73	73	73	73	85	85	98	110	128	140	160
<b>Peso Weight Kg</b>	1.97	1.97	2.01	2.42	3.96	4.98	7.08	9.76	16.87	24.72	36.99



### T4.622/L4.622 + AP

Attuatori pneumatici  
Pneumatic actuator

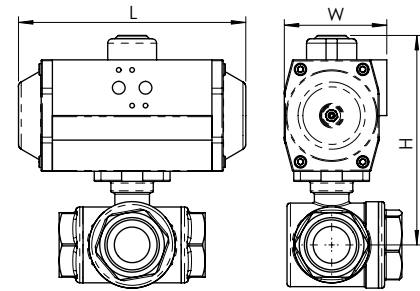

DN	1/4"	3/8"	1/2"	3/4"	1"	1" 1/4"	1" 1/2"	2"
<b>04.622 + AP DE - DA</b>	AP1	AP1	AP1	AP2	AP2	AP3	AP3	AP3.5
L	142	142	142	155	155	213	213	236
H	124	124	124	144	150	176	180	201
W	60	60	60	73	73	85	85	98
<b>Peso Weight Kg</b>	1.7	1.67	1.63	2.36	2.81	5.45	6.2	9.99
<b>04.622 + AP SE - SPRING RETURN</b>	AP2S	AP2S	AP2S	AP3S	AP3S	AP3.5S	AP4S	AP4.5S
L	155	155	155	213	213	236	276	310
H	140	140	140	161	167	186	205	303
W	73	73	73	85	85	98	110	128
<b>Peso Weight Kg</b>	2.26	2.23	2.19	4.04	4.49	7.21	9.86	15.98

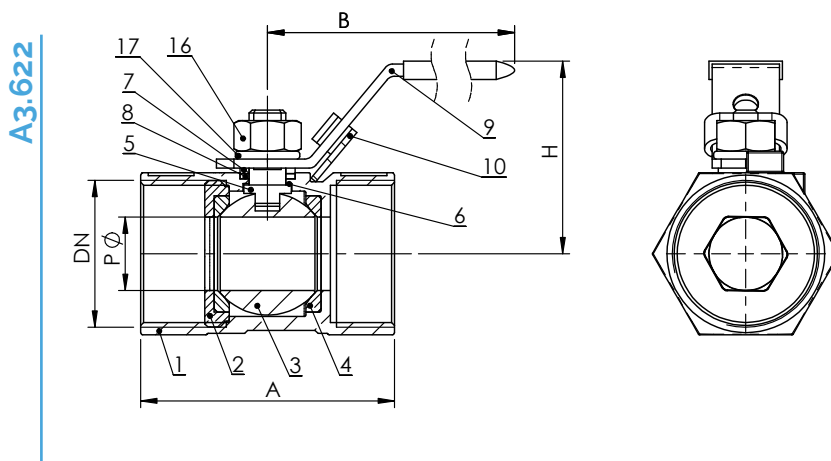

### Dimensioni (mm) / Dimensions (mm)

DN	1/4"	3/8"	1/2"	3/4"	1"	1" 1/4	1" 1/2	2"
P	5	7	9,5	12,5	16	20	25	32
A	40	45	56	59	71	76	85	99
B	67	67	93	93	103	103	128	128
H	32	33	43	45	48	58	67	74

### Peso (kg) / Weight (kg)

A3.622	0,09	0,12	0,19	0,28	0,39	0,58	0,85	1,35
--------	------	------	------	------	------	------	------	------

### Coppia di manovra (Nm) / Operating torque (Nm)

Nm	4	4	6	6	8	10	14	15
----	---	---	---	---	---	----	----	----

N.B. al fine di ottimizzare la scelta del servocomando si consiglia di moltiplicare il momento torcente per il coefficiente di sicurezza K=1,5  
 N.B.: In order to choose the right actuator, we recommend multiplying the operating torque figure by a safety coefficient, K=1.5

### Materiali / Materials

	Componente - Component	Materiale - Material
1	Corpo - Body	Acciaio inox - Stainless steel ASTM A351 CF8M
2	Ghiera - Cap	Acciaio inox - Stainless steel ASTM A351 CF8M
3	Sfera - Ball	Acciaio inox - Stainless steel AISI 316
4	Sede sfera - Ball seat	PTFE caricato - Reinforced PTFE
5	Asta - Stem	Acciaio inox - Stainless steel AISI 316
6	Anello antifrizione - Sliding washer	PTFE
7	Ghiera - Ring	Acciaio inox - Stainless steel AISI 304
8	Tenuta stelo - Stem seal	PTFE
9	Leva - Lever	AISI 304 con guaina in plastica - AISI 304 with plastic sleeve
10	Dispositivo di bloccaggio - Lock device	Acciaio inox - Stainless steel AISI 304
16	Dado - Nut	Acciaio inox - Stainless steel AISI 304
17	Rosetta elastica - Spring washer	Acciaio inox - Stainless steel AISI 304



B3.622

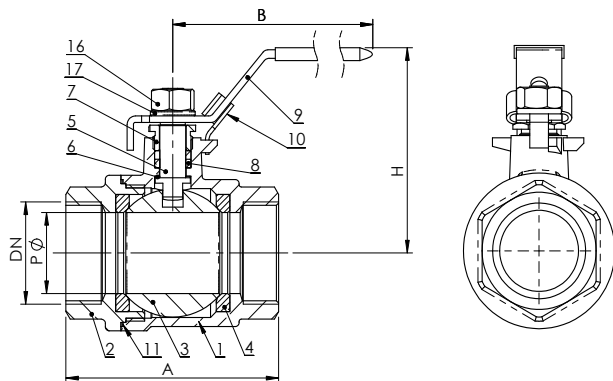

B3.622 ISO

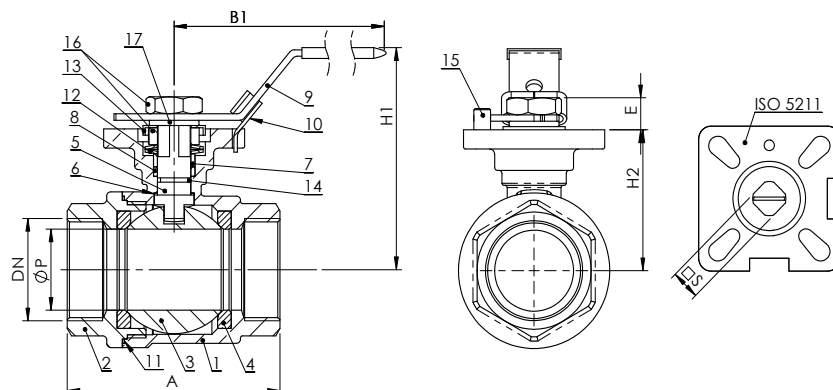

## Dimensioni (mm) / Dimensions (mm)

DN	1/4"	3/8"	1/2"	3/4"	1"	1" 1/4	1" 1/2	2"	2" 1/2	3"	4"
P	11,5	12,5	15	20	25	32	40	50	65	76	94
A	49	49	57	64	77	90	105	125	154	173	221
B	105	105	105	118	150	150	182	182	254	254	285
H	54	54	56	65	70	75	93	99	123	140	175
A1	56	56	57	64	77	90	105	125	153	172	221
B1	115	115	117	117	134	134	203	203	254	254	302
H1	65	65	65	70	75	85	95	105	140	145	175
H2	37	37	37	43	46	54	60	68	93	109	121
E	8	8	9	11	11	12,5	12,5	12	17	16	19
S	9	9	9	9	11	11	14	14	17	17	17
ISO 5211	F03	F03	F03/F04	F03/F04	F04/F05	F04/F05	F05/F07	F05/F07	F07/F10	F07/F10	F07/F10

## Peso (kg) / Weight (kg)

B3.622	0,23	0,23	0,24	0,45	0,65	1,05	1,7	2,61	5,01	7,61	14,75
B3.622 with ISO flange	0,37	0,35	0,37	0,49	0,74	1,18	1,94	2,90	5,77	8,45	15,60

## Coppia di manovra (Nm) / Operating torque (Nm)

Nm	5	5	5	8	10	14	18	25	48	75	110
----	---	---	---	---	----	----	----	----	----	----	-----

N.B. al fine di ottimizzare la scelta del servocomando si consiglia di moltiplicare il momento torcente per il coefficiente di sicurezza K=1,5

N.B.: In order to choose the right actuator, we recommend multiplying the operating torque figure by a safety coefficient, K=1.5

## Materiali / Materials

	Componente - Component	Materiale - Material
1	Corpo - Body	Acciaio inox - Stainless steel ASTM A351 CF8M
2	Ghiera - Cap	Acciaio inox - Stainless steel ASTM A351 CF8M
3	Sfera - Ball	Acciaio inox - Stainless steel AISI 316
4	Sede sfera - Ball seat	PTFE caricato - Reinforced PTFE
5	Asta - Stem	Acciaio inox - Stainless steel AISI 316
6	Anello antifrizione - Sliding washer	PTFE
7	Ghiera - Ring	Acciaio inox - Stainless steel AISI 304
8	Tenuta stelo - Stem seal	PTFE
9	Leva - Lever	AISI 304 con guaina in plastica - AISI 304 with plastic sleeve
10	Dispositivo di bloccaggio - Lock device	Acciaio inox - Stainless steel AISI 304
11	Tenuta corpo - Body seal	PTFE
12	Molla Belleville - Belleville Spring	Acciaio inox - Stainless steel AISI 301
13	Distanziale - Spacer	Acciaio inox - Stainless steel AISI 304
14	O Ring - O-ring	FKM (Viton®)
15	Piolo fermo leva - Lever stop pin	Acciaio inox - Stainless steel AISI 304
16	Dado - Nut	Acciaio inox - Stainless steel AISI 304
17	Rosetta elastica - Spring washer	Acciaio inox - Stainless steel AISI 304

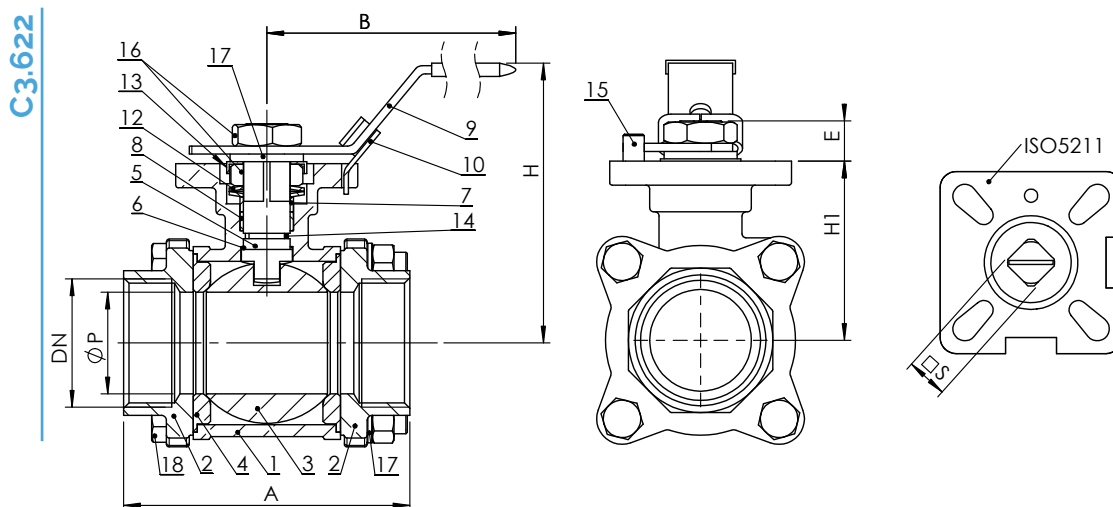

### Dimensioni (mm) / Dimensions (mm)

DN	1/4"	3/8"	1/2"	3/4"	1"	1" 1/4	1" 1/2	2"	2" 1/2	3"	4"
P	11	12,5	15	20	25	32	40	50	65	76	94
A	48	48	54	73	80	90	102	118	151	182	218
B	115	115	117	134	134	203	203	203	255	255	302
H	59	59	63	70	74	88	94	102	140	153	166
H1	33	33	37	42	46	54	60	68	100	113	126
E											
S	9	9	9	11	11	14	14	14	17	17	17
ISO 5211	F03	F03	F03	F04/F05	F04/F05	F05/F07	F05/F07	F05/F07	F07/F10	F07/F10	F07/F10

### Peso (kg) / Weight (kg)

C3.622	0,41	0,40	0,45	0,86	1,22	1,88	2,78	3,56	7,20	12,10	19,90
--------	------	------	------	------	------	------	------	------	------	-------	-------

### Coppia di manovra (Nm) / Operating torque (Nm)

Nm	4	4	5	8	10	14	18	25	48	75	110
----	---	---	---	---	----	----	----	----	----	----	-----

N.B. al fine di ottimizzare la scelta del servocomando si consiglia di moltiplicare il momento torcente per il coefficiente di sicurezza K=1,5  
 N.B.: In order to choose the right actuator, we recommend multiplying the operating torque figure by a safety coefficient, K=1.5

### Materiali / Materials

	Componente - Component	Materiale - Material
1	Corpo - Body	Acciaio inox - Stainless steel ASTM A351 CF8M
2	Ghiera - Cap	Acciaio inox - Stainless steel ASTM A351 CF8M
3	Sfera - Ball	Acciaio inox - Stainless steel AISI 316
4	Sede sfera - Ball seat	PTFE caricato - Reinforced PTFE
5	Asta - Stem	Acciaio inox - Stainless steel AISI 316
6	Anello antifrizione - Sliding washer	PTFE
7	Ghiera - Ring	Acciaio inox - Stainless steel AISI 304
8	Tenuta stelo - Stem seal	PTFE
9	Leva - Lever	AISI 304 con guaina in plastica - AISI 304 with plastic sleeve
10	Dispositivo di bloccaggio - Lock device	Acciaio inox - Stainless steel AISI 304
12	Molla Belleville - Belleville Spring	Acciaio inox - Stainless steel AISI 301
13	Distanziale - Spacer	Acciaio inox - Stainless steel AISI 304
14	O Ring - O-ring	FKM (Viton®)
15	Piolo fermo leva - Lever stop pin	Acciaio inox - Stainless steel AISI 304
16	Dado - Nut	Acciaio inox - Stainless steel AISI 304
17	Rosetta elastica - Spring washer	Acciaio inox - Stainless steel AISI 304
18	Tirante - Tie rod	Acciaio inox - Stainless steel AISI 304

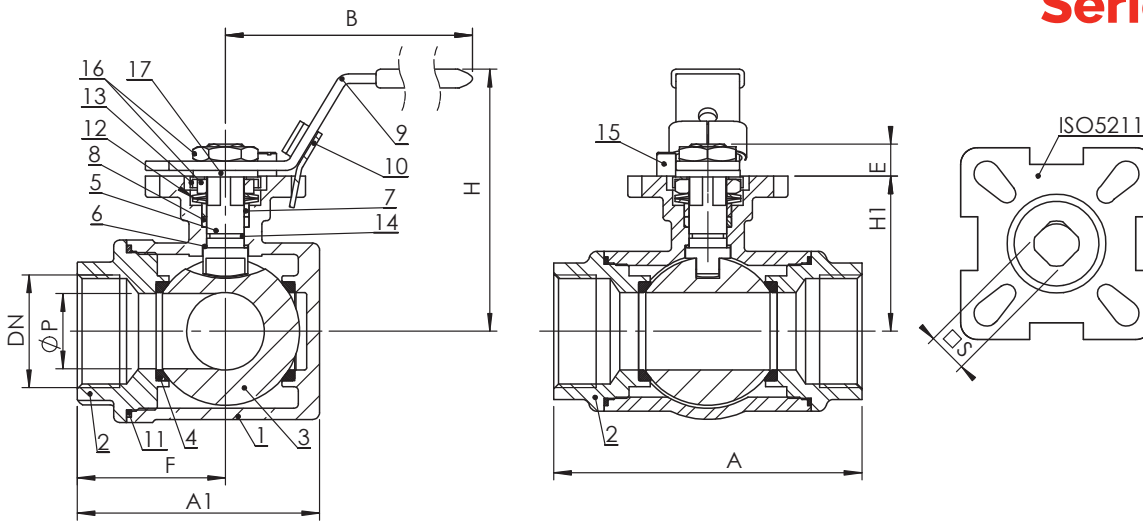

## Dimensioni (mm) / Dimensions (mm)

DN	1/4"	3/8"	1/2"	3/4"	1"	1" 1/4	1" 1/2	2"
P	9,5	11	12	15	20	25	32	40
A	75	75	75	85	100	122	131	158
A1	57,5	57,5	57,5	65,5	79	97	106,5	129
F	37,5	37,5	37,5	42,5	50	61	65,5	79
B	130	130	130	161	161	203	203	203
H	66	66	66	2	77	92	96	107
H1	37	37	37	41	47	56	60	71
E	8,5	8,5	8,5	11	12	13,5	13,5	13
S	9	9	9	11	11	14	14	14
ISO 5211	F03/F04	F03/F04	F03/F04	F04/F05	F04/F05	F05/F07	F05/F07	F05/F07

## Peso (kg) / Weight (kg)

04.622	0,7	0,67	0,63	0,94	1,39	2,91	3,66	6,31
--------	-----	------	------	------	------	------	------	------

## Coppia di manovra (Nm) / Operating torque (Nm)

Nm	8	8	8	9	15	20	30	45
----	---	---	---	---	----	----	----	----

N.B. al fine di ottimizzare la scelta del servocomando si consiglia di moltiplicare il momento torcente per il coefficiente di sicurezza K-1,5  
 N.B.: In order to choose the right actuator, we recommend multiplying the operating torque figure by a safety coefficient, K=1.5

## Materiali / Materials

	Componente - Component	Materiale - Material
1	Corpo - Body	Acciaio inox - Stainless steel ASTM A351 CF8M
2	Ghiera - Cap	Acciaio inox - Stainless steel ASTM A351 CF8M
3	Sfera - Ball	Acciaio inox - Stainless steel AISI 316
4	Sede sfera - Ball seat	PTFE caricato - Reinforced PTFE
5	Asta - Stem	Acciaio inox - Stainless steel AISI 316
6	Anello antifrizione - Sliding washer	PTFE
7	Ghiera - Ring	Acciaio inox - Stainless steel AISI 304
8	Tenuta stelo - Stem seal	PTFE
9	Leva - Lever	AISI 304 con guaina in plastica - AISI 304 with plastic sleeve
10	Dispositivo di bloccaggio - Lock device	Acciaio inox - Stainless steel AISI 304
12	Molla Belleville - Belleville Spring	Acciaio inox - Stainless steel AISI 301
13	Distanziale - Spacer	Acciaio inox - Stainless steel AISI 304
14	O Ring - O-ring	FKM (Viton®)
15	Piolo fermo leva - Lever stop pin	Acciaio inox - Stainless steel AISI 304
16	Dado - Nut	Acciaio inox - Stainless steel AISI 304
17	Rosetta elastica - Spring washer	Acciaio inox - Stainless steel AISI 304
18	Tirante - Tie rod	Acciaio inox - Stainless steel AISI 304

	Serie	Vie collegate / Connected port
	L4.622	
	T4.622	

Valvola a sfera filettata in acciaio AISI 316 F/F / AISI 316 F/F threaded end ball valves

## Pressione massima / Maximum pressure

Articolo - Article	bar
A3.622	63 bar
B3.622	63 bar
C3.622	63 bar
C3.622	63 bar
04.622	63 bar

## Temperatura / Temperature

Temperatura - Temperature	min °C	max °C - Max °C
	-25	180

Attenzione: la pressione massima di utilizzo diminuisce con la temperatura, vedi diagramma "Pressione/Temperatura"

NB: the maximum working pressure decreases while the temperature increases; please refer to "pressure/temperature" chart

## Diagramma Pressione/Temperatura - Pressure/temperature chart

### Serie A3.622 / 04.622

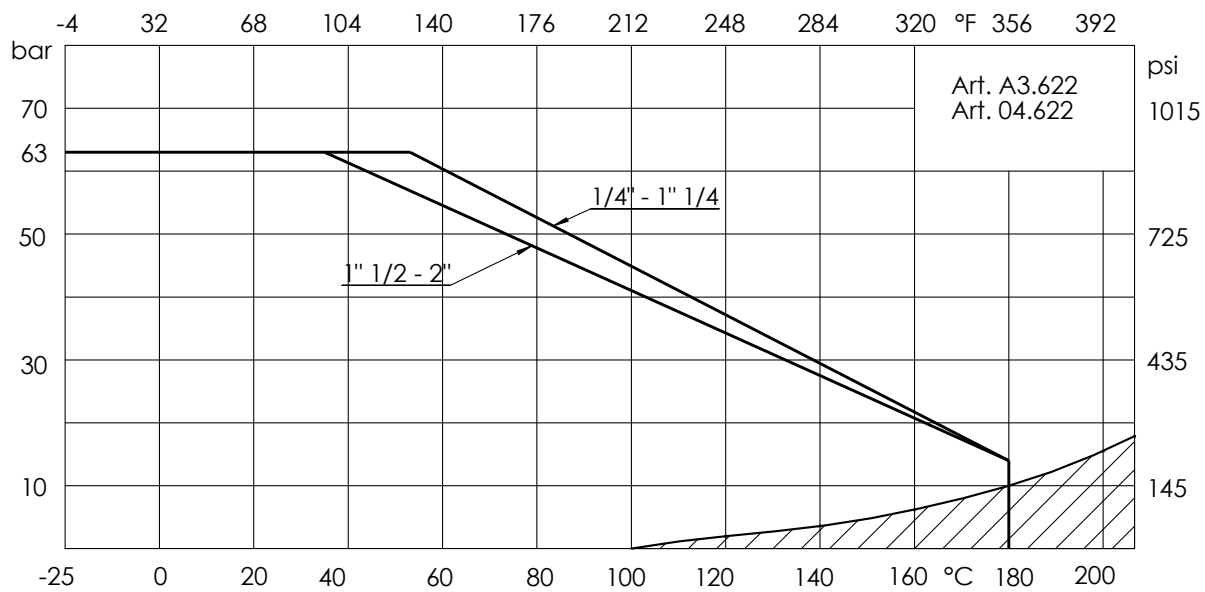

### Serie B3.622 / C3.622

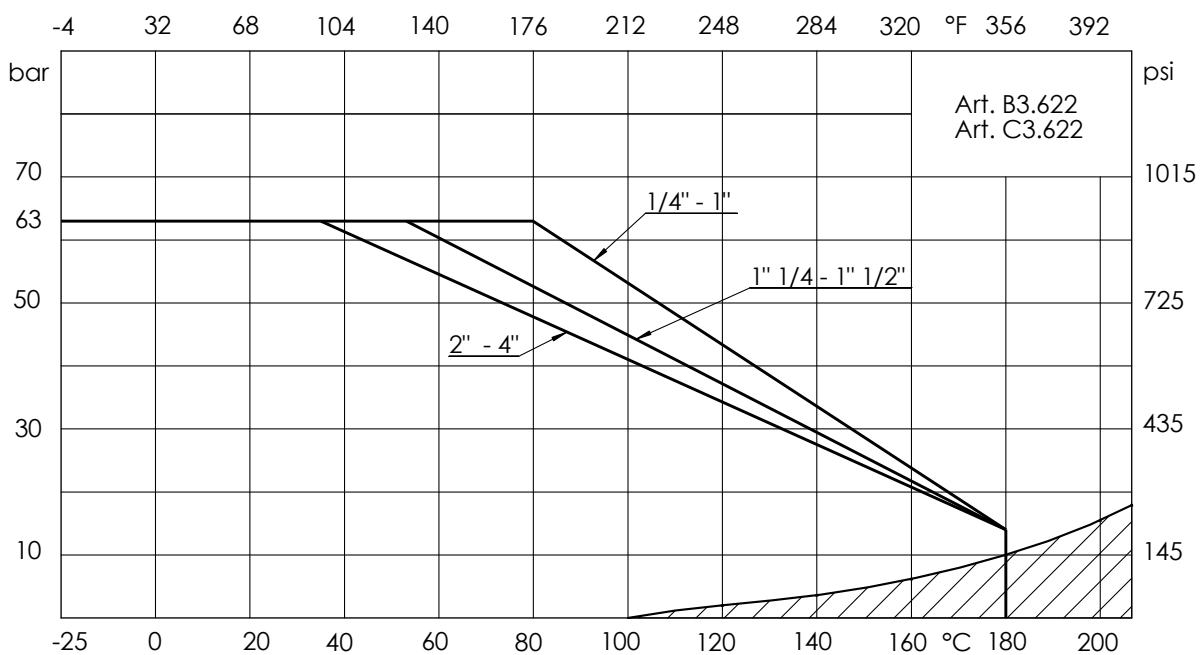

**NON ADATTA PER VAPORE.** NON utilizzare in condizioni di temperature e pressione al di sotto della curva di saturazione liquido-vapore (area tratteggiata)  
**RANGE NOT SUITABLE FOR STEAM.** DO NOT use when temperature and pressure are below the liquid-steam saturation line (hatched area)



**Perdite di carico Fluido: acqua (1m H<sub>2</sub>O = 0,098bar) - Perdite di carico ad otturatore completamente aperto**

**Head loss Fluid: water (1m H<sub>2</sub>O = 0,098bar) - Head loss with shutter fully opened**

**Serie A3.622 / 04.622**

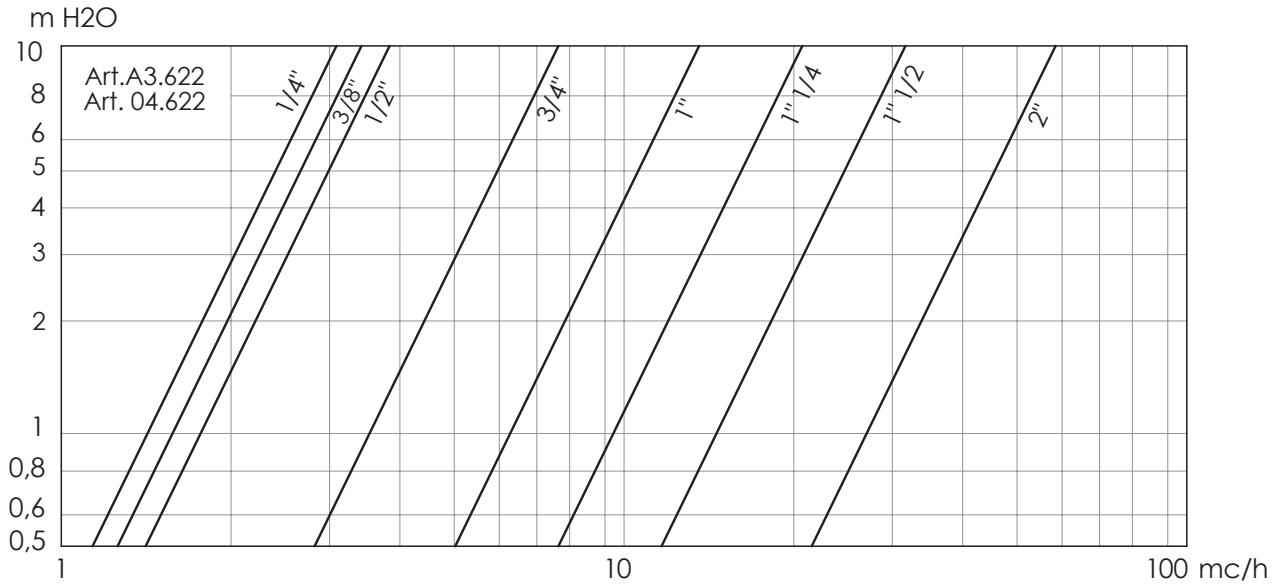

**Serie B3.622 / C3.622**

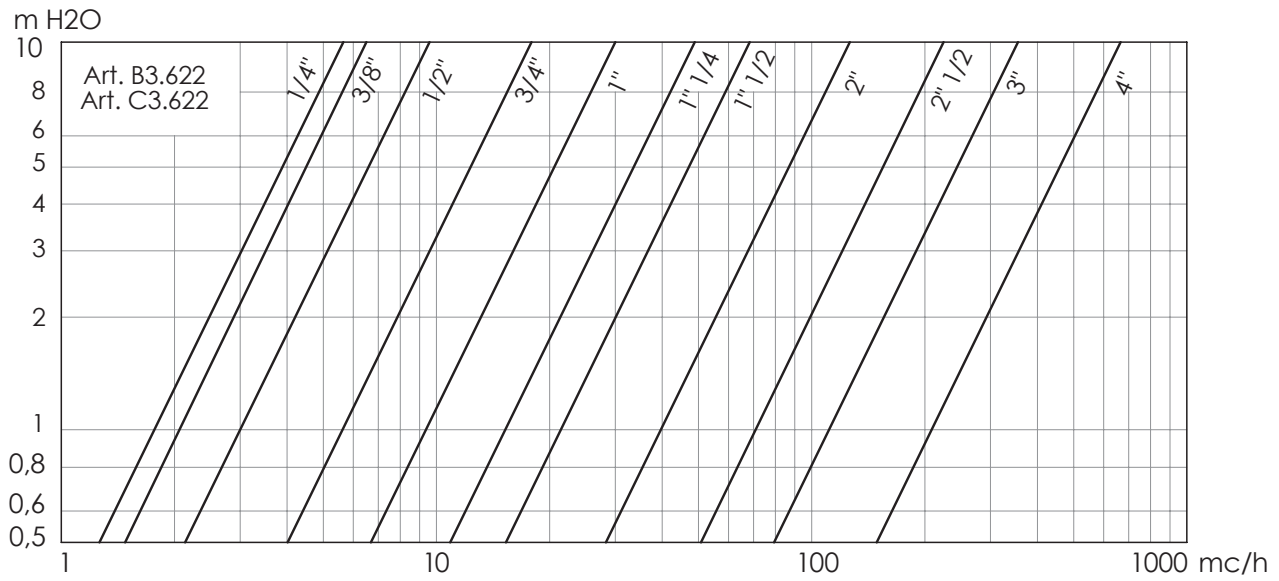

**Tabella Kv - DN / Kv - DN chart**

DN	1/4"	3/8"	1/2"	3/4"	1"	1" 1/4"	1" 1/2"	2"	2" 1/2"	3"	4"	
A3.622 - 04.622	Kv mc/h	3,2	3,4	3,8	7,7	13,7	20,5	31,5	58	-	-	-
B3.622 - C3.622	Kv mc/h	5,6	6,8	9,6	17,9	30	49	68	126	226	355	667

## Istruzioni e Avvertenze per le serie 03-04 inox

### **STOCCAGGIO**

Conservare in ambiente chiuso e asciutto.

### **MANUTENZIONE**

La valvola non prevede manutenzione.

### **AVVERTENZE**

Prima di procedere a qualunque intervento di manutenzione o smontaggio:

- attendere il raffreddamento di tubazioni, valvola e fluido,
  - scaricare la pressione e drenare linea e tubazioni in presenza di fluidi tossici, corrosivi, infiammabili o caustici.
- Temperature oltre i 50°C e sotto gli 0° C possono causare danni alle persone.

### **INSTALLAZIONE**

- Maneggiare con cura.
- La valvola deve essere installata in posizione aperta o chiusa.
- I colpi d'ariete possono causare danni e rotture. Inclinazioni, torsioni e disallineamenti delle tubazioni possono causare sollecitazioni improprie sulla valvola una volta installata. Raccomandiamo di evitarli per quanto possibile o adottare giunti elastici che possano attenuarne gli effetti.
- A temperature inferiori allo zero, il fluido contenuto tra corpo e sfera può congelare e causare danni irreparabili.  
Se la valvola è esposta a tali condizioni raccomandiamo di isolare la valvola.
- Si raccomanda di manovrare periodicamente le valvole a sfera per evitare il deposito di materiali sulla sfera e sulle sedi.

### **SMALTIMENTO**

Se la valvola opera a contatto con fluidi tossici o pericolosi, prendere le necessarie precauzioni ed effettuare pulizia dai residui eventualmente intrappolati nella valvola. Il personale addetto deve essere adeguatamente istruito ed equipaggiato dei necessari dispositivi di protezione.

Prima dello smaltimento, smontare la valvola e suddividere i componenti in base al tipo di materiale. Consultare le schede prodotto per maggiori informazioni. Avviare i materiali così suddivisi al riciclaggio (per es. materiali metallici) o allo smaltimento, in accordo alla legislazione locale in vigore e nel rispetto dell'ambiente.

## Instructions and Recommendations for series 03-04 inox

### **STORING**

Keep in a dry and closed place.

### **MAINTENANCE**

The valve does not require maintenance.

### **RECOMMENDATIONS**

Before carrying out maintenance, or dismantling the valve, be sure that the pipes, valves and liquids have cooled down, that the pressure has decreased and that the lines and pipes have been drained in case of toxic, corrosive, inflammable or caustic liquids.

Temperatures above 50°C and below 0°C might cause damage to people.

### **INSTALLATION**

- Handle with care.
- The valve must be installed in either the ON or OFF position.
- Water hammers might cause damage and ruptures. Inclination, torsions and misalignments of the piping may subject the installed valve to excessive stresses. It is recommended that elastic joints be used in order to reduce such effects as much as possible.
- At sub-zero temperatures, the liquid between the body and ball may freeze, causing irreparable damage. If the valve is exposed to such conditions, insulation of the valve is recommended.
- It is recommended that the valve be operated periodically, to prevent the build-up of materials on the ball and the seats.

### **DISPOSAL**

For valve operating with hazardous media (toxic, corrosive...), if there is a possibility of residue remaining in the valve, take due safety precaution and carry out required cleaning operation. Personnel in charge must be trained and equipped with appropriate protection devices.

Prior to disposal, disassemble the valve and separate the component according to various materials. Please refer to product literature for more information. Forward sorted material to recycling (e.g. metallic materials) or disposal, according to local and currently valid legislation and under consideration of the environment.