

# Serie 05



Valvola di ritegno a molla  
*Spring check valve*

DOWNLOAD  
DATASHEET



**b**-Smart, Be-Brandoni



**brandoni**  
VALVES

[www.brandonivalves.com](http://www.brandonivalves.com)

## Valvola di ritegno a molla / Spring check valve

Le valvole serie 05 sono valvole di ritegno con corpo in ghisa grigia, realizzate in accordo alle normative di prodotto rilevanti ed al sistema di gestione della qualità EN ISO 9001. Sono disponibili in versione flangiata dal DN50 al DN300 ed in versione filettata dal DN50 al DN100.

Sono adatte per riscaldamento e condizionamento (HVAC), trattamento e distribuzione dell'acqua, per acqua potabile, gruppi di pompaggio, applicazioni agricole, industriali, antincendio, per aria compressa, oli e idrocarburi.

*(Fatta salva la scelta corretta dell'articolo in base all'applicazione)*

**Sono idonee:** per installazione in linea (in posizione orizzontale o verticale) e come valvola di fondo.

La forma del corpo e dell'otturatore minimizza le turbolenze e le perdite di carico.

**Non sono idonee:** per vapore.

### Accessori

Tappi di spurgo

Rubinetti di spurgo

Cestello filtrante (vedi sez. Filtrazione)

### Esecuzioni speciali

Gruppo doppia ritegno

The valves in Series 05 are check valves with cast iron bodies, that are manufactured in accordance with the most severe product norms, and in conformity with the quality requirements of EN ISO 9001. They are available in flanged versions, from DN 50 to DN 300, and in threaded versions, from DN 50 to DN 100.

The valves are suitable for installation in heating and conditioning plants (HVAC), for water treatment and distribution, for drinking water, pump stations, agricultural applications, industrial applications, fire fighting applications, for compressed air, oils and hydrocarbons.

*(Please ensure the choice of the corresponding item)*

**YES:** for in-line installation (horizontal or vertical position) and as foot valves.

The shape of the body and shutter minimizes turbulence and head loss.

**NO:** for steam.

### Accessories

Plugs for drain

Mini-valves for drain

Filter baskets (see Filtration)

### Special version

Double check group

## Certificazioni / Certifications



Conformi alla direttiva 2014/68/EU (ex 97/23/CE PED)

Conformi al D.M. 174 (direttiva 98/83/CE)

**Norme costruttive e di collaudo** (equivalenti):

Flange: EN 1092 ISO 7005

Filetto: ISO228-1

Design: EN12516, EN12334

Marcatura: EN19

Collaudo: testate al 100% EN 12266, grado A

In conformity with directive 2014/68/UE (ex 97/23/CE PED)

In conformity with D.M. 174 (directive 98/83/CE)

**Design and testing standards** (correspondences) :

Flanges: EN 1092 ISO 7005

Threading: ISO228-1

Design: EN12516, EN12334

Marking: EN19

Testing: 100% tested according to EN 12266, leakage rate A

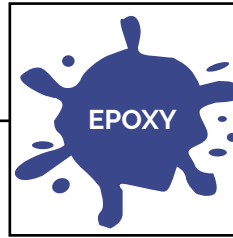

Serie F5.008/018: vernice epossidica FBE RAL 5015 certificata Wras.

Serie T5: verniciatura interna ed esterna con smalto epossidico, resistente alle alte temperature RAL 5002. Vernice a base acqua, a basso impatto ecologico.

*F5.008/018 series: 5015 RAL FBE epoxy coating, Wras approved.*

*T5 series: internal and external 5002 RAL epoxy coatings, highly temperature resistant. Environmentally friendly water-based paint.*

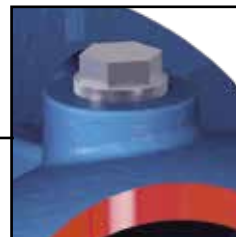

A richiesta: prese filettate per spurgo, by-pass.

*On request: threaded holes for drain, by-pass*

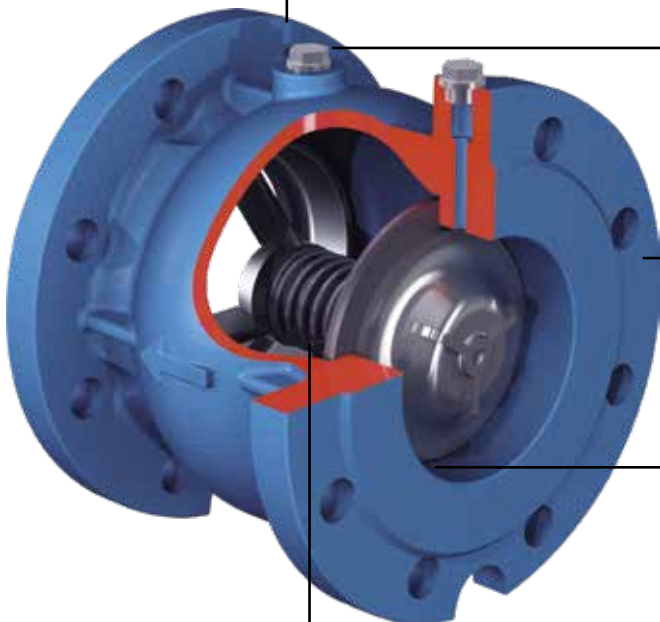

La forma del corpo e dell'otturatore minimizza le turbolenze e le perdite di carico.

*The shape of body and shutter minimizes turbulence and head loss.*

Tenuta piana in NBR, FKM (Viton®) o gomma idonea per acqua potabile.

*Flat seal in NBR, FKM (Viton®) or rubber suitable for drinking water.*

La molla in acciaio inox permette il montaggio in ogni posizione.

*The stainless steel spring allows the valves to be assembled in any position.*



## Valvola di ritegno a molla / Spring check valve

### F5 Flangiata / Flanged

NBR

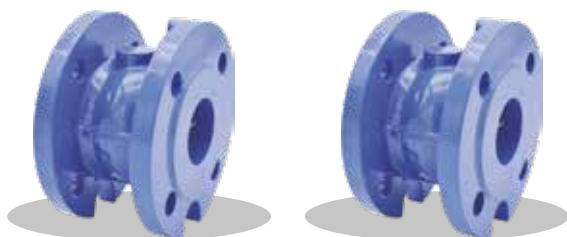

#### F5.000

Corpo: ghisa grigia  
Interno:  
DN 50-100: Ottone  
DN 125-250: ghisa grigia  
DN 300: ghisa sferoidale  
Tenuta: NBR  
Temp: da -10 a +100°C

Body: cast iron  
Trim material:  
DN 50-100: Brass  
DN 125-250: cast iron  
DN 300: ductile iron  
Seal: NBR  
Temp: -10 +100°C

#### F5.010

Corpo: ghisa grigia  
Interno: AISI304  
Tenuta: NBR  
Temp: da -10 a +100°C

Body: cast iron  
Trim material: AISI304  
Seal: NBR  
Temp: -10 +100°C

FKM

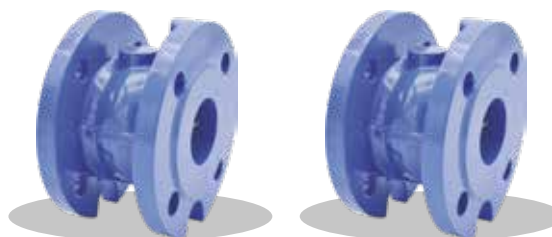

#### F5.002

Corpo: ghisa grigia  
Interno:  
DN 50-100: Ottone  
DN 125-250: ghisa grigia  
DN 300: ghisa sferoidale  
Tenuta: FKM  
Temp: da -10 a +150°C

Body: cast iron  
Trim material:  
DN 50-100: Brass  
DN 125-250: cast iron  
DN 300: ductile iron  
Seal: FKM  
Temp: -10 +150°C

#### F5.012

Corpo: ghisa grigia  
Interno: AISI304  
Tenuta: FKM  
Temp: da -10 a +150°C

Body: cast iron  
Trim material: AISI304  
Seal: FKM  
Temp: -10 +150°C

### F5 Flangiata / Flanged

EPDM

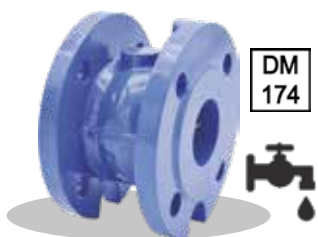

#### F5.008

Corpo: ghisa grigia  
Interno:  
DN 50-100: Ottone  
DN 125-250: ghisa grigia  
DN 300: ghisa sferoidale  
Tenuta: EPDM Wras  
Temp: da -10 a +70°C  
**Approvato ACS**

Body: cast iron  
Trim material:  
DN 50-100: Brass  
DN 125-250: cast iron  
DN 300: ductile iron  
Seal: suitable for drinking water Wras EPDM  
Temp: -10 +70°C  
**ACS approved**

EPDM

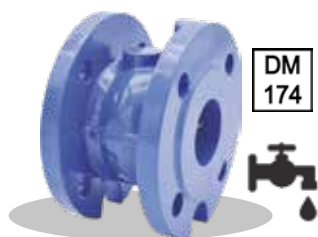

#### F5.018

Corpo: ghisa grigia  
Interno: AISI304  
Tenuta: EPDM Wras  
Temp: da -10 a +70°C  
**Approvato ACS**

Body: cast iron  
Trim material: AISI304  
Seal: suitable for drinking water Wras EPDM  
Temp: -10 +70°C  
**ACS approved**

### T5 Filettata / Threaded F/F

NBR



#### T5.000

Corpo: ghisa grigia  
Interno: Ottone  
Tenuta: NBR  
Temp: da -10 a +100°C

Body: cast iron  
Trim material: Brass  
Seal: NBR  
Temp: -10 +100°C

FKM



#### T5.002

Corpo: ghisa grigia  
Interno: Ottone  
Tenuta: FKM  
Temp: da -10 a +150°C

Body: cast iron  
Trim material: Brass  
Seal: FKM  
Temp: -10 +150°C

## Valvole di fondo / Foot valve

### Flangiate / Flanged



#### F5.000 + 50

Corpo: ghisa grigia  
Interno: Ottone  
DN 50-100: Ottone  
DN 125-250: ghisa grigia  
DN 300: ghisa sferoidale  
Tenuta: NBR  
Temp: da -10 a +100°C  
Cestello filtrante: acciaio ZN

Body: cast iron  
Trim material:  
DN 50-100: Brass  
DN 125-250: cast iron  
DN 300: ductile iron  
Seal: NBR  
Temp: -10 +100°C  
Strainer: galvanized steel



#### F5.010/018 + 52

Corpo: ghisa grigia  
Interno: AISI304  
Tenuta: NBR/ EPDM  
Temp: da -10 a +100°C  
Cestello filtrante: AISI 304

Body: cast iron  
Trim material: AISI304  
Seal: NBR/ EPDM  
Temp: -10 +100°C  
Strainer: AISI 304



#### F5.010/018 + 53

Corpo: ghisa grigia  
Interno: AISI304  
Tenuta: NBR/ EPDM  
Temp: da -10 a +100°C  
Cestello filtrante: AISI 316

Body: cast iron  
Trim material: AISI304  
Seal: NBR/ EPDM  
Temp: -10 +100°C  
Strainer: AISI 316

### Filettate / Threaded



#### T5.000 + 51

Corpo: ghisa grigia  
Interno: Ottone  
Tenuta: NBR  
Temp: da -10 a +100°C  
Cestello filtrante: AISI 304

Body: cast iron  
Trim material: Brass  
Seal: NBR  
Temp: -10 +100°C  
Strainer: AISI 304

## Accessori / Accessories

### Tappi di spurgo / Plugs for drain

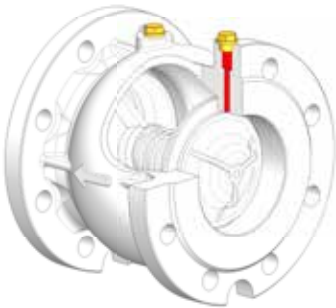

Tappi in AISI 304 1/4"

1/4" AISI 304 plugs



Tappi in AISI 304 1/4"

1/4" AISI 304 plugs

### Rubinetti di spurgo / Mini-valves for drain



Rubinetti in ottone M/F 1/4",  
tappo in plastica

1/4", M/F brass mini-valves,  
with plastic cap



Rubinetti in ottone M/F 1/4",  
tappo in plastica

1/4", M/F brass mini-valves,  
with plastic cap

## Gruppo doppia ritegno / Double check group

### Flangiata / Flanged

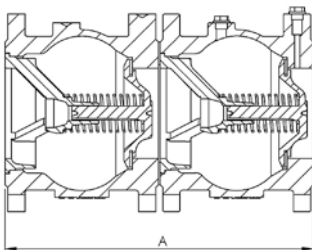

DN	40	50	65	80	100	125	150	200	250	300
A	202	202	242	282	342	402	462	602	742	802
kg	13,2	13,2	17,2	21,6	29,6	43,2	59,2	99,2	164,8	222

### Filettata/ Threaded

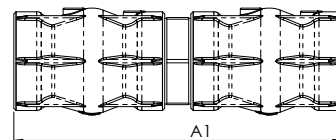

DN	50	65	80	100
	2"	2 1/2"	3"	4"
A	310	364	384	450
kg	4,5	6,6	8,8	15,5

## Valvola di ritegno a molla / Spring check valve

F5 DN50 - 150

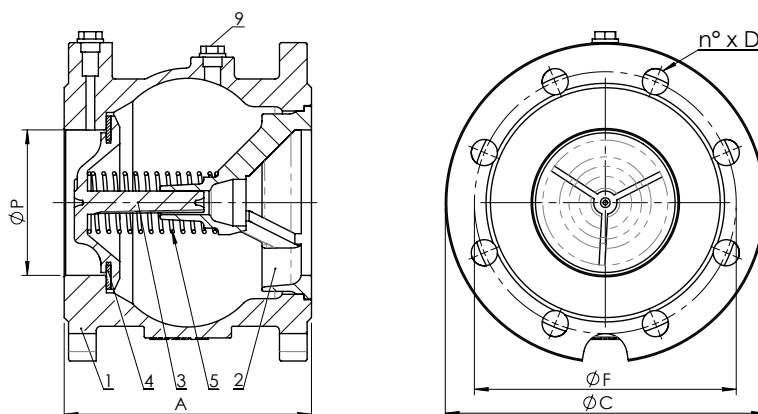

F5 DN200 - 300

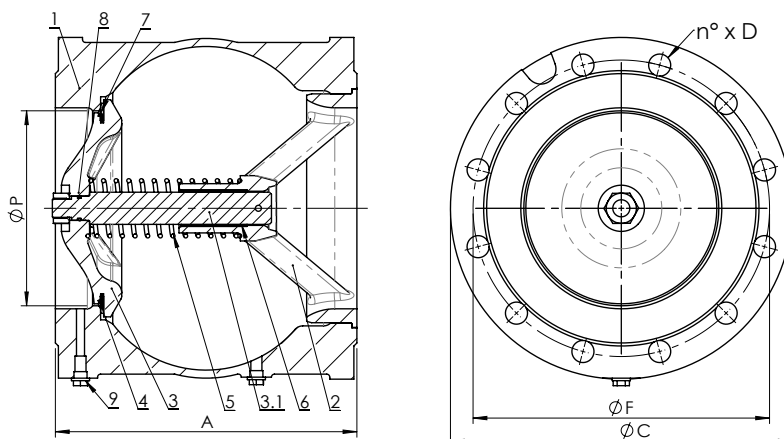

### Dimensioni (mm) / Dimensions (mm)

DN		40	50	65	80	100	125	150	200	250	300
P		40	50	65	80	100	125	145	194	242	285
A	Non normalizzato - Not standardized	100	100	120	140	170	200	230	300	370	400
C		165	165	185	200	220	250	285	340	405	460
F	EN 1092 PN16	110	125	145	160	180	210	240	295	355	410
n° x D		4 x M16	4 x 18	4 x 18	8 x 18	8 x 18	8 x 18	8 x 22	12 x 22	12 x 26	12 x 27

### Peso (kg) / Weight (kg)

F5	4,5	5,6	7,6	9,8	13,8	20,6	28,6	48,6	81,4	111
----	-----	-----	-----	-----	------	------	------	------	------	-----

### Materiali / Materials

	Componente - Component	Materiale
1	Corpo - Body	Ghisa grigia - Cast iron EN GJL 250
2	Guida stelo DN50-100 - Stem guide DN50-100	Ottone - Brass CuZn40Pb2 Acciaio inox - Stainless steel ASTM A351 gr. CF8M/ASTM A351 gr. CF8
	Guida stelo DN125-250 - Stem guide DN125-250	Ghisa grigia - Cast iron EN GJL 250 Acciaio inox - Stainless steel ASTM A351 gr. CF8M/ASTM A351 gr. CF8
3	Guida stelo DN300 - Stem guide DN300	Ghisa sferoidale - Ductile iron EN GJS 400-15
	Otturatore DN50-100 - Shutter DN 50-100	Ottone - Brass CuZn40Pb2 Acciaio inox - Stainless steel ASTM A351 gr. CF8
	Otturatore DN125-250 - Shutter DN 125-250	Ghisa grigia - Cast iron EN GJL 250 Acciaio inox - Stainless steel ASTM A351 gr. CF8
3.1	Otturatore DN300 - Shutter DN300	Ghisa sferoidale - Ductile iron EN GJS 400-15
	Stelo otturatore - Shutter stem	Ottone - Brass CuZn40Pb2 Acciaio inox - Stainless steel ASTM A351 gr. CF8
4	Guarnizione - Gasket	NBR / FKM (Viton®) / EPDM
5	Molla - Spring	AISI 304
6	Bussola - Bushing (solo dal DN 125 al 250 con interni in ghisa - only from DN 125 to 250 with cast iron trim material)	Ottone - Brass
7	Anello antiestrazione DN200-300 - Anti-blow out ring	AISI 302
8	O-Ring DN200-300 - O-ring DN 200-300	NBR / FKM (Viton®) / EPDM
9	Tappi - Plug	AISI 304 + O-Ring NBR / FKM (Viton®) / EPDM

T5

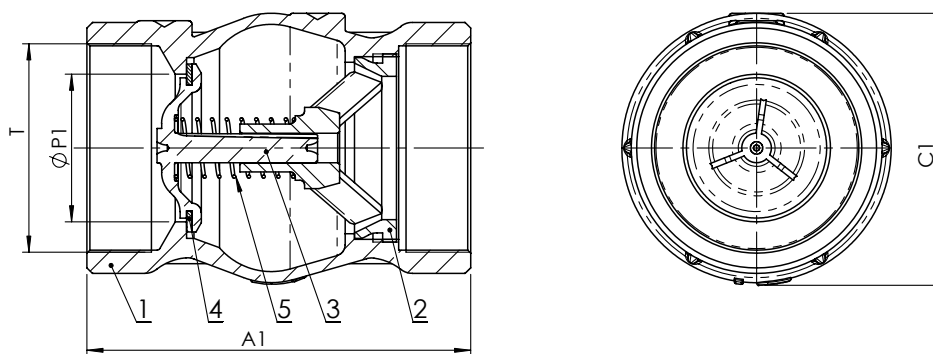

## Dimensioni (mm) / Dimensions (mm)

DN		50	65	80	100
T	ISO 228-1	2"	2" -1/2	3"	4"
P1		50	64	64	80
A1	Non normalizzato - Not standardized	140	167	177	208
C1		96	125	125	148

## Peso (kg) / Weight (kg)

T5		2.2	3.2	4.2	7.4

## Materiali / Materials

	Componente - Component	Materiale
1	Corpo - Body	Ghisa grigia - Cast iron EN GJL 250
2	Guida stelo - Stem guide	Ottone - Brass CuZn40Pb2 Acciaio inox - Stainless steel ASTM A351 gr. CF8M
3	Otturatore - Shutter	Ottone - Brass CuZn40Pb2 Acciaio inox - Stainless steel ASTM A351 gr. CF8M
4	Guarnizione - Gasket	NBR / FKM (Viton®)
5	Molla - Spring	AISI 302



F5 + 50

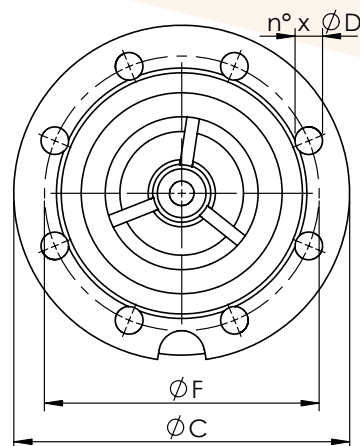
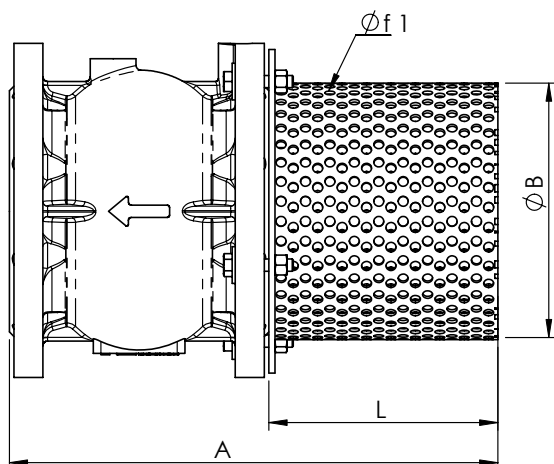

T5 + 51

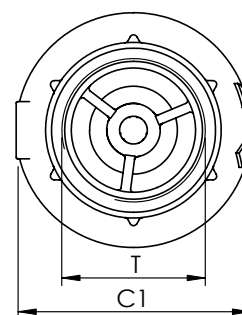
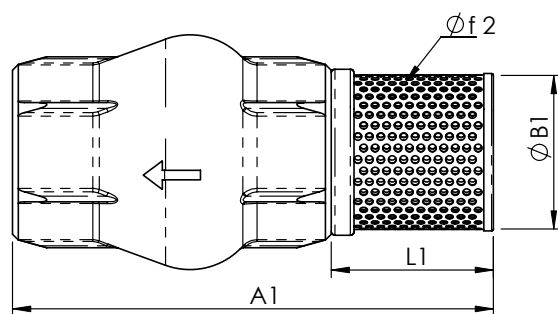

### Dimensioni (mm) / Dimensions (mm)

DN		40	50	65	80	100	125	150	200	250	300
A	Non normalizzato - Not standardized	180	180	220	260	320	375	430	550	670	750
L		80	80	100	120	150	175	200	250	300	350
B		111	111	131	148	168	198	222	278	329	390
C		165	165	185	200	220	250	285	340	405	460
F	EN 1092 PN16	110	125	145	160	180	210	240	295	355	410
n° x D		4 x M16	4 x 18	4 x 18	8 x 18	8 x 18	8 x 18	8 x 22	12 x 22	12 x 26	12 x 27
T	ISO 228-1	-	2"	2" -1/2	3"	4"	-	-	-	-	-
A1	Non normalizzato - Not standardized	-	225	252	282	326	-	-	-	-	-
L1		-	85	85	105	118	-	-	-	-	-
C1		-	96	125	125	148	-	-	-	-	-
f1		5	5	5	5	5	5	5	5	5	5
f2		-	1.2	1.2	1.2	1.2	-	-	-	-	-

### Peso (kg) / Weight (kg)

kg	F5+50/52/53	5,05	6,15	8,34	10,73	15	22,2	30,8	51,8	85,8	118
kg	T5+51	-	2,27	3,29	4,31	7,55	-	-	-	-	-

### Pressione minima di apertura (mmH2O) / Cracking pressure (mmH2O)

Direzione flusso Flow direction	DN	40	50	65	80	100	125	150	200	250	300
		955	639	647	592	624	570	526	639	690	654
		764	382	316	280	318	180	165	221	204	266
		860	510	480	436	470	375	345	429	448	460
	senza molla without spring	95	125	165	155	152	203	185	208	244	194



## Pressione massima / Maximum pressure

Tipo fluido* - Fluids*	
Gas pericolosi - Hazardous gases G1	NO
Gas non pericolosi - Non-hazardous gases G2	16 bar DN 50-200 14 bar DN 250 11 bar DN 300
Liquidi pericolosi - Hazardous liquids L1	16 bar DN 50-125 13 bar DN 150 10 bar DN 200-300
Liquidi non pericolosi - Non-hazardous liquids L2	16 bar
Acqua** - Water**	16 bar

\* gas, liquidi pericolosi secondo 2014/68/EU e 1272/2008 (CLP)

\*\* Per la raccolta, distribuzione e deflusso di acqua (PED 2014/68/EU 112b)

\* hazardous gas, liquids acc. 2014/68/EU e 1272/2008 (CLP)

\*\* For supply, distribution and discharge of water (PED 2014/68/EU 112b)

## Temperatura / Temperature

Temperatura - Temperature	min °C	max °C			
		continuo - conti- nuos		picco - peak	
		L1	G2,L2	L1	G2,L2
NBR	-10	100	100	-	110
FKM (Viton®)	-10	100	150	-	170
Gomma per acqua potabile Rubber for drinking water	-10	-	70	-	-

Attenzione: la pressione massima di utilizzo diminuisce con la temperatura, vedi diagramma "Pressione/Temperatura" G1, L12, G2, L2: vedi tabella a lato  
NB: the maximum working pressure decreases while the temperature increases; please refer to "pressure/temperature" chart G1, L12, G2, L2: see chart to side

## Diagramma Pressione/Temperatura - Pressure/temperature chart

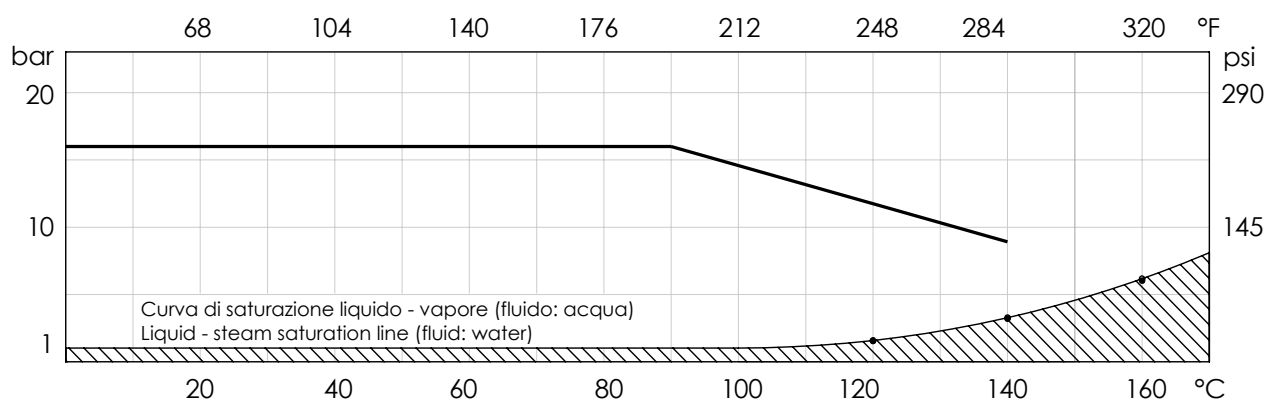

**NON ADATTA PER VAPORE.** NON utilizzare in condizioni di temperature e pressione al di sotto della curva di saturazione liquido-vapore (area tratteggiata)  
**RANGE NOT SUITABLE FOR STEAM.** DO NOT use in case temperature and pressure are below the saturation line liquid-steam (hatched area)

## Perdite di carico Fluido: acqua (1m H<sub>2</sub>O = 0,098bar) / Head loss Fluid: water (1m H<sub>2</sub>O = 0,098bar)

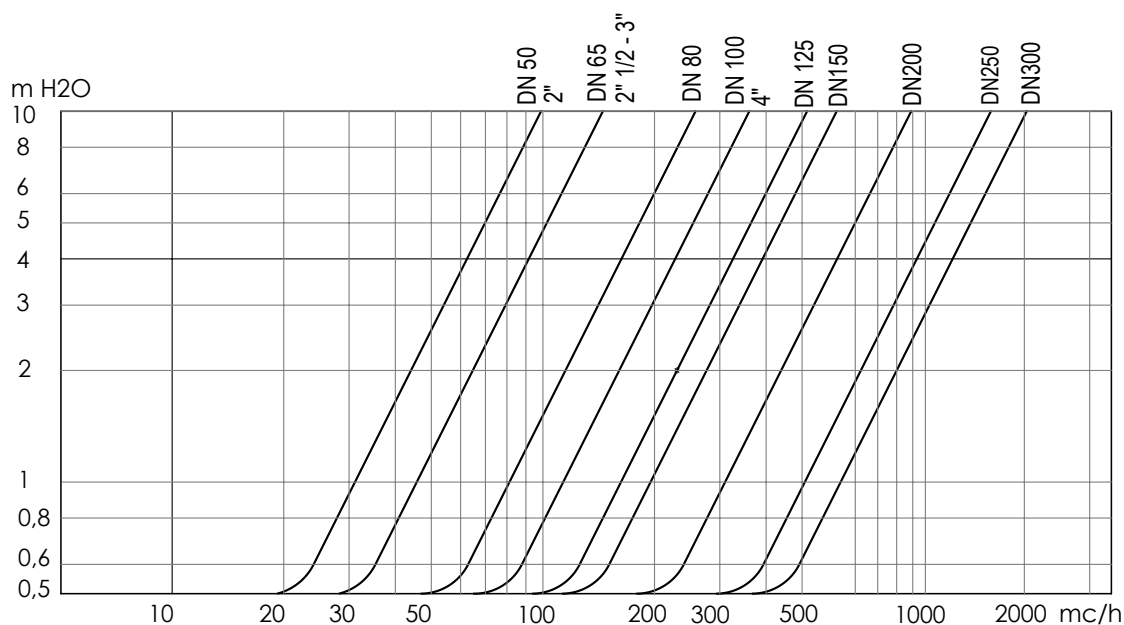

## Tabella Kv - DN / Kv-DN chart

DN	40	50	65	80	100	125	150	200	250	300
Kv	99	99	145	258	360	516	620	985	1620	2016

## Istruzioni e Avvertenze per le serie 05

### STOCCAGGIO

Conservare in ambiente chiuso e asciutto.

### MANUTENZIONE

La valvola non prevede manutenzione.

### AVVERTENZE

Prima di procedere a qualunque intervento di manutenzione o smontaggio:

- attendere il raffreddamento di tubazioni, valvola e fluido,
- scaricare la pressione e drenare linea e tubazioni in presenza di fluidi tossici, corrosivi, infiammabili o caustici.

Temperature oltre i 50°C e sotto gli 0° C possono causare danni alle persone.

### INSTALLAZIONE

- Maneggiare con cura.
- Posizionare la valvola tra le flange della tubazione e inserire le guarnizioni di tenuta tra le flange della valvola e le flange della tubazione. Verificare che le guarnizioni siano posizionate correttamente. La distanza tra le controflange deve essere pari allo scartamento della valvola. Non utilizzare i bulloni delle controflange per avvicinare la tubazione. I bulloni devono essere stretti in croce.
- Le flange non devono essere saldate alle tubazioni dopo che la valvola è stata installata.
- I colpi d'ariete possono causare danni e rotture. Inclinazioni, torsioni e disallineamenti delle tubazioni possono causare sollecitazioni improprie sulla valvola una volta installata. Raccomandiamo di evitarli per quanto possibile o adottare giunti elastici che possano attenuarne gli effetti.
- Alcune valvole in posizione aperta presentano un ingombro maggiore dello scartamento nominale. Prevedere nell'installazione un'adeguata distanza per evitare interferenze che possano provocare danni o malfunzionamenti (vedi Fig. 1 a titolo esemplificativo).

**NOTA.** Questa valvola è unidirezionale: installare secondo il senso del flusso indicato sul corpo.

### SMALTIMENTO

Se la valvola opera a contatto con fluidi tossici o pericolosi, prendere le necessarie precauzioni ed effettuare pulizia dai residui eventualmente intrappolati nella valvola. Il personale addetto deve essere adeguatamente istruito ed equipaggiato dei necessari dispositivi di protezione.

Prima dello smaltimento, smontare la valvola e suddividere i componenti in base al tipo di materiale. Consultare le schede prodotto per maggiori informazioni. Avviare i materiali così suddivisi al riciclaggio (per es. materiali metallici) o allo smaltimento, in accordo alla legislazione locale in vigore e nel rispetto dell'ambiente.

FIG. 1

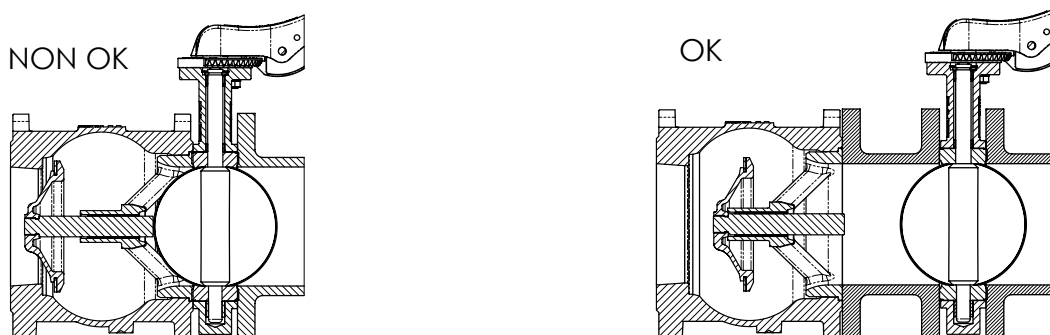

## Instructions and Recommendations for series 05

### STORING

Keep in a closed and dry place.

### MAINTENANCE

The valve does not require maintenance.

### RECOMMENDATIONS

Before carrying out maintenance or dismantling the valve:

- be sure that the pipes, valves and fluids have cooled down,
- that the pressure has decreased and that the lines and pipes have been drained in case of toxic, corrosive, inflammable and caustic liquids.

Temperatures above 50°C and below 0°C might cause damage to people.

### INSTALLATION

- Handle with care.
- Place the valve between the flanges of the pipe and install the seal between the pipe and valve flanges. Check that the seals have been positioned correctly.
- The distance between the counter flanges must be equal to the valve's face to face distance. Do not use bolts of the counter flanges to bring the piping close to the valve. The bolts should be cross tightened.
- Do not weld the flanges to the piping after installing the valve.
- Water hammers might cause damage and ruptures. Inclination, twisting and misalignments of the piping may subject the installed valve to excessive stresses. It is recommended that elastic joints be used in order to reduce such effects as much as possible.
- When in the open position, some valves have a larger dimension than the nominal face to face value. A suitable distance should be allowed for when assembling, in order to prevent damage or malfunctioning (see fig. 1 for example).

**NOTE.** This valve is unidirectional: install in accordance with the flow direction arrow indicated on the body.

### DISPOSAL

For valve operating with hazardous media (toxic, corrosive...), if there is a possibility of residue remaining in the valve, take due safety precaution and carry out required cleaning operation. Personnel in charge must be trained and equipped with appropriate protection devices. Prior to disposal, disassemble the valve and separate the component according to various materials. Please refer to product literature for more information. Forward sorted material to recycling (e.g. metallic materials) or disposal, according to local and currently valid legislation and under consideration of the environment.

I dati e le caratteristiche di questo catalogo sono forniti a titolo indicativo. La Brandoni S.p.A. si riserva di modificare una o più caratteristiche delle valvole senza preavviso. Per maggiori informazioni [www.brandonivalves.com](http://www.brandonivalves.com).

Brandoni SpA reserves the right to make changes in design and/or construction of the products at any time without prior notice. For further information, please refer to [www.brandonivalves.com](http://www.brandonivalves.com)