

Serie B2.3



Valvola a sfera flangiata in bronzo
Flanged bronze ball valve

DOWNLOAD
DATASHEET



b-Smart, Be-Brandoni



brandoni
VALVES

www.brandonivalves.com

Valvola a sfera flangiata in bronzo / Flanged bronze ball valve

Le valvole serie B2.3 sono valvole di intercettazione a sfera tipo split-body con corpo in bronzo e sfera flottante, realizzate in accordo alle normative di prodotto rilevanti ed al sistema di gestione della qualità EN ISO 9001.

La serie è disponibile nelle versioni:

B2 > con scartamento EN 558-1 a passaggio pieno

R2 > con scartamento ANSI B16.10#150 short pattern a passaggio ridotto

S2 > con scartamento ANSI B16.10#150 short pattern a passaggio pieno

Sono adatte per applicazioni navali, Offshore e in ambiente marino, per riscaldamento e condizionamento (HVAC), tele-riscaldamento, trattamento e distribuzione dell'acqua, applicazioni industriali, chimiche, agricole, per aria compressa, oli e idrocarburi. (Fatta salva la scelta corretta dell'articolo in base all'applicazione)

Sono idonee: per impieghi in linea e a fine linea, e per servizio che richieda frequenti azionamenti; il supporto integrato in accordo a ISO 5211 permette il facile montaggio di una ampia gamma di servocomandi.

Le valvole a sfera serie B2 presentano un passaggio pieno e diritto che minimizza le turbolenze e le perdite di carico.

Non sono idonee: per vapore, per la parzializzazione e regolazione della portata.

Accessori

- Prolunga per isolamento termico
- Cappuccio quadro per presa stradale
- Prolunga per presa stradale
- Kit flangia ISO 5211
- Kit Leva di manovra lucchettabile
- Kit interruttori di finecorsa per segnalazione Aperto/Chiuso

Comandi

- Attuatori pneumatici a doppio e semplice effetto
- A richiesta: box finecorsa, posizionatore
- Attuatori elettrici
- Riduttori manuali
- Riduttori manuali con comando a catena

Certificazioni / Certifications



Conformi alla Direttiva 2014/68/UE (ex 97/23/CE PED)
Conformi al D.M. 174 (direttiva 98/83/CE), per utilizzo a contatto con acqua potabile.

Norme costruttive e di collaudo (equivalenti):

Flange: EN 1092 ISO 7005, ANSI B16.5 #150

Design: EN 1983, EN12516, ISO 5211

Marcatura: EN19

Collaudo: testate al 100% EN 12266 cat. A (ISO 5208 cat. A)

Series B2.3 valves are split-body-type, shut-off ball valves in bronze and floating ball, manufactured in accordance with the relevant product standards and quality management of ISO 9001.

This series is available also:

B2 > with face to face, in accordance with EN 558-1 full bore

R2 > with face to face, in accordance with ANSI B16.10#150 short pattern reduced bore

S2 > with face to face, in accordance with ANSI B16.10#150 short pattern full bore

Suitable for naval, Offshore and seawater applications, heating and conditioning (HVAC), district heating, distribution and treatment of water, industrial and chemical applications, agricultural applications, for compressed air processing, oils and hydrocarbons.

(Please ensure the choice of the corresponding item)

YES: for installation in-line and end of line, for services with frequent acting, the integrated ISO 5211 support allows the installation of a wide range of actuators.

The B2 range of ball valves of full and straight bores, reduce turbulences and minimize head loss.

NO: for steam, for choking and regulation of the flow.

Accessories

- Stem extension for thermal insulation
- Square cap for water main system connection
- Stem extension
- Kit lockable operation lever
- Kit limit switches for ON/OFF position indicator
- KIT ISO 5211 flange

Actuators

- Double acting and single acting pneumatic actuators
- On request: limit switches, position indicator
- Electric actuators
- Gear boxes
- Chain driven operated gear boxes

In conformity with directive 2014/68/UE (ex 97/23/CE PED)
Suitable for drinking water application, comply with Italian regulation D.M.174

Design and testing standards (correspondences):

Flanges: EN 1092 ISO 7005, ANSI B16.5 #150

Design: EN 1983, EN12516, ISO 5211

Marking: EN19

Testing: 100% testing in accordance with EN 12266 cat. A (ISO 5208 cat. A)



Scartamento secondo EN558/1 o ANSI B16.10
 Classe 150 short pattern per tutti i DN .
Face to face, in accordance with EN558/1 or ANSI B 16.10 class 150 short pattern for all DN (diameters).

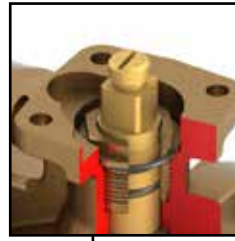

Flangia in accordo a ISO 5211 integrata.
Integrated flange, in accordance with ISO 5211.

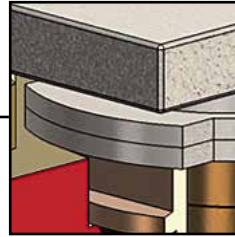

Sfilando una piastrina e ruotandola di 90° è possibile bloccare la leva in posizione aperta o chiusa.
Removing and repositioning of the plate at 90° allows locking of the lever in ON-OFF position.

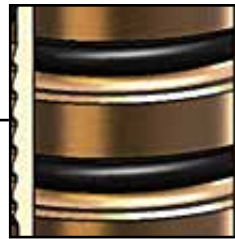

Il doppio O-Ring sullo stelo e la busola metallica garantiscono la tenuta dinamica anche nelle condizioni più gravose.
The dynamic seal of the stem is guaranteed by a double O-ring, even in severe working conditions.

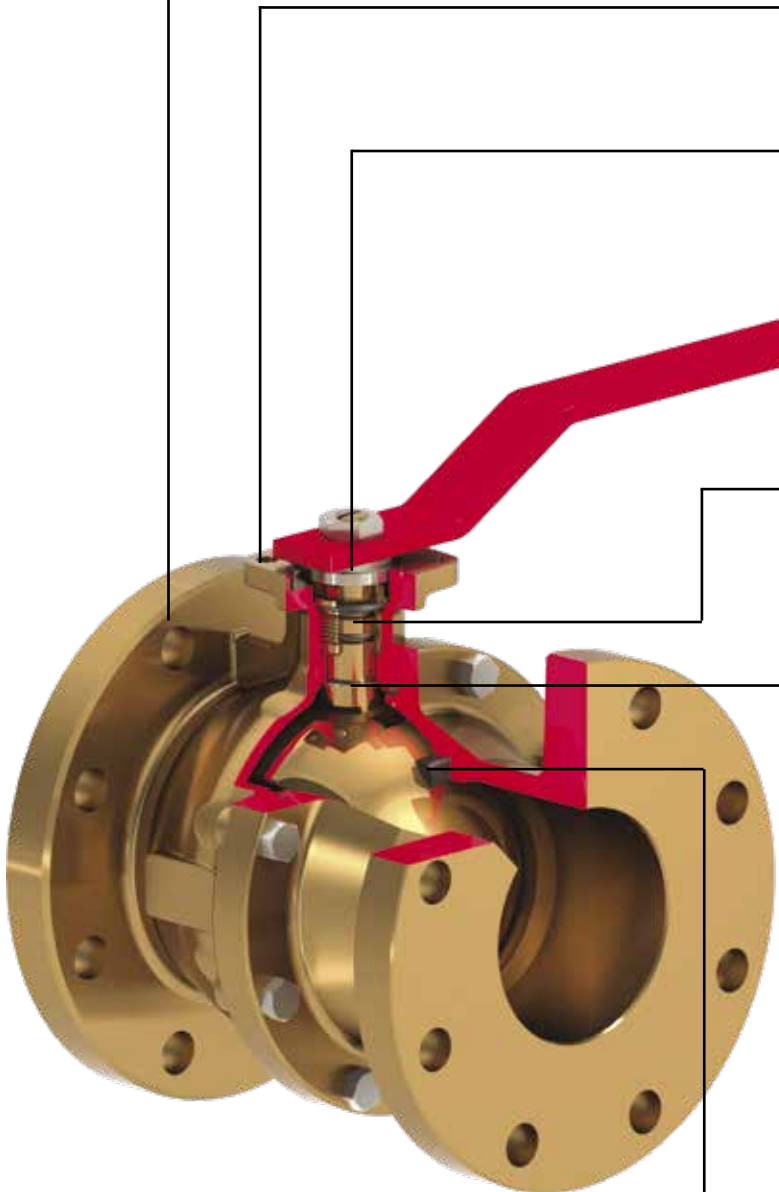

Stelo con design antiespulsione.
 Dispositivo antistatico (EN17292) a richiesta.
*Blow-out proof stem.
 On request antistatic device (EN17292)*

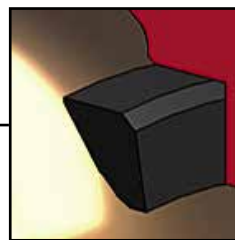

Sede sfera in PTFE caricato, al variare della temperatura la coppia di manovra rimane costante.
Seat of ball in reinforced PTFE, as temperature changes, the torque remains constant.

Valvola a sfera flangiata in bronzo / Flanged bronze ball valve

Scartamento / Face to face EN 558/1 - 14*



B2.300

Corpo: Bronzo
Sfera: Ottone
Asta: Ottone
O-ring: FKM
Temp: da -10 a +150°C

Body: Bronze
Ball: Brass
Stem: Brass
O-ring: FKM
Temp: -10 +150°C



B2.322

Corpo: Bronzo
Sfera: AISI 316
Asta: AISI 316
O-ring: FKM
Temp: da -10 a +150°C

Body: Bronze
Ball: AISI 316
Stem: AISI 316
O-ring: FKM
Temp: -10 +150°C



B2.377

Corpo: Bronzo
Sfera: Bronzo-alluminio
Asta: Bronzo-alluminio
O-ring: FKM
Temp: da -10 a +150°C

Body: Bronze
Ball: Aluminium-bronze
Stem: Aluminium-bronze
O-ring: FKM
Temp: -10 +150°C

*Flange: PN16, ANSI 150
*Flanges: PN 16, ANSI 150

Scartamento / Face to face ANSI B16.10#150 - passaggio ridotto / reduced bore**

Scartamento / Face to face ANSI B16.10#150 - passaggio pieno / full bore**



S2.300

Corpo: Bronzo
Sfera: Ottone
Asta: Ottone
O-ring: FKM
Temp: da -10 a +150°C

Body: Bronze
Ball: Brass
Stem: Brass
O-ring: FKM
Temp: -10 +150°C



S2.322

Corpo: Bronzo
Sfera: AISI 316
Asta: AISI 316
O-ring: FKM
Temp: da -10 a +150°C

Body: Bronze
Ball: AISI 316
Stem: AISI 316
O-ring: FKM
Temp: -10 +150°C



S2.377

Corpo: Bronzo
Sfera: Bronzo-alluminio
Asta: Bronzo-alluminio
O-ring: FKM
Temp: da -10 a +150°C

Body: Bronze
Ball: Aluminium-bronze
Stem: Aluminium-bronze
O-ring: FKM
Temp: -10 +150°C



R2.377

Corpo: Bronzo
Sfera: Bronzo-alluminio
Asta: Bronzo-alluminio
O-ring: FKM
Temp: da -10 a +150°C

Body: Bronze
Ball: Aluminium-bronze
Stem: Aluminium-bronze
O-ring: FKM
Temp: -10 +150°C

**Flange: ANSI 150
**Flanges: ANSI 150

I componenti ed accessori realizzati in acciaio NON inox, anche se protetti da verniciatura, zincatura o altro trattamento, se utilizzati in ambienti all'aperto, in condizioni di forte umidità/condensa od in ambienti aggressivi, possono mostrare una durata di protezione all'ossidazione limitata nel tempo.
Components and accessories made in steel different from stainless steel, even if protected by painting or galvanizing, if used in outdoor environments, in conditions of high humidity / condensation or in aggressive environments, may exhibit a limited protection span against oxidation.

Comandi e accessori / Actuators and accessories



B2.3-S2.3 + RM

Riduttore manuale
Gear box

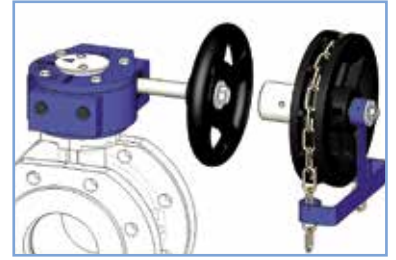
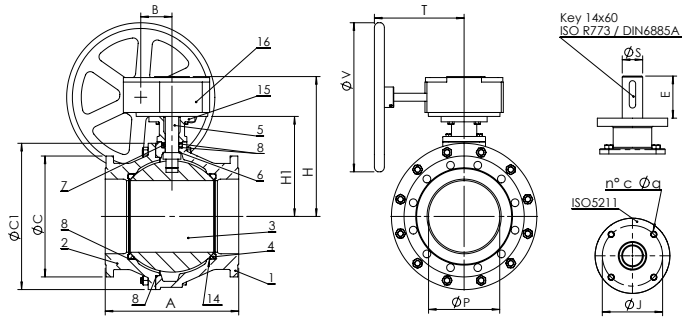

KCAT

Kit comando a catena
Chain driver kit

DN	15	20	25	32	40	50	65	80	100	125	150	200	250
Bz/S2 + RM	RM.0250	RM.0250	RM.0250	RM.0250	RM.0250	RM.0250	RM.0250	RM.0250	RM.0250	RM.0750	RM.0750	RM.1200	RM.1200
L	130	130	130	130	130	130	130	130	130	180	180	205	256
U	77	77	77	77	77	77	77	77	77	104	104	124	101
H	112,5	114	121	126	140,5	149	157	180	194,5	243	260,5	310	448
W	225	225	225	225	225	225	225	225	225	338	338	345	464
G	170	170	170	170	170	170	170	170	170	260	260	260	360
V	150	150	150	150	150	150	150	150	150	300	300	300	500
Peso / Weight Kg	6,9	7,6	8,5	10,1	11,8	13,3	14,8	19,8	22,8	38,3	48,8	105,3	192,3



B2.3-S2.3 + AOX

Attuatori elettrici
Electric actuators

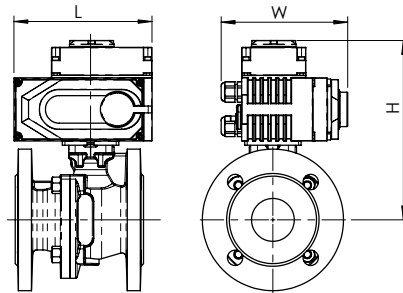

DN	15	20	25	32	40	50	65	80	100	125	150	200
Bz/S2 + AOX	003	003	003	003	005	005	008	015	015	030	040	100
L	123	123	123	123	160	160	160	189	189	268	268	268
H	164	165	172	177	200	208	216	247	262	329	347	394
W	100	100	100	100	121	121	121	145	145	225	225	225
Peso / Weight Kg	4,7	5,4	6,3	7,9	11,1	12,6	14,1	20,1	23,1	41,4	52,3	107,5



B2.3-S2.3 + AP

Attuatori pneumatici
Pneumatic actuator

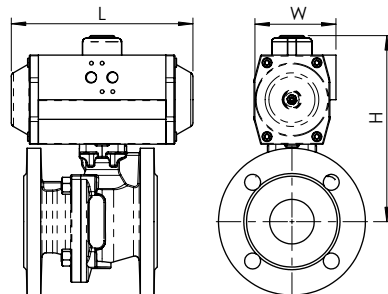

DN	15	20	25	32	40	50	65	80	100	125	150	200	250
Bz/S2 + AP DE - DA	AP052	AP052	AP052	AP063	AP063	AP063	AP075	AP092	AP105	AP125	AP140	AP190	AP270
L	147	147	147	165	165	165	182	262	270	298	395	528	721
H	182,5	184	191	212	186,5	195	215	255	285,5	329	374,5	570	793
W	3,8	4,5	5,4	7,8	9,5	11	13,1	20,1	24,5	36,7	52,5	126,2	258,7
Peso / Weight Kg	4	4,6	6	7,6	9,9	12,5	17,7	23,7	30	45,4	58,6	137,2	198,7
Bz/S2 + AP SE - SPRING RETURN	AP075S	AP075S	AP075S	AP075S	AP083S	AP083S	AP092S	AP125S	AP140S	AP160S	AP190S	AP270S	AP400S
L	182	182	182	182	208	208	262	298	395	454	528	721	925
H	210,5	212	219	224	207,5	216	232	282	384,5	382	522,5	668	821
W	95	95	95	95	103	103	109	134	153	174	206	294	516
Peso / Weight Kg	5,66	6,26	7,66	8,46	11,5	14,1	20,5	29,1	40,5	61,1	84,8	204	405

Comandi e accessori / Actuators and accessories

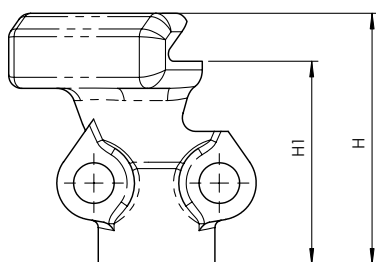
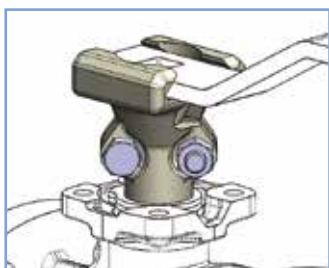

DN	25-32-40-50-65	80-100-125-150
H	68	68
H1	55	55

KITB2

Prolunga per isolamento termico / Stem extension for thermal insulation

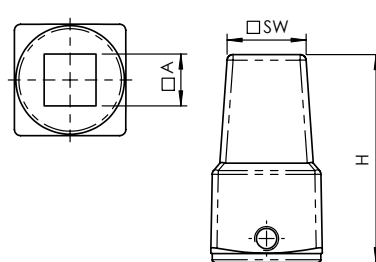
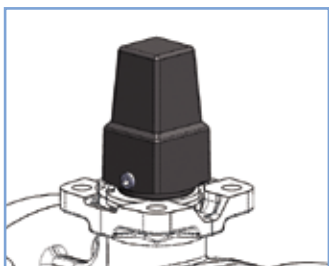

DN	40-50-65	80-100	125-150
SW	26	26	26
A	14	17	22
H	69	69	71

KCAPB2

Cappuccio quadro per presa stradale / Square cap for water main system connection

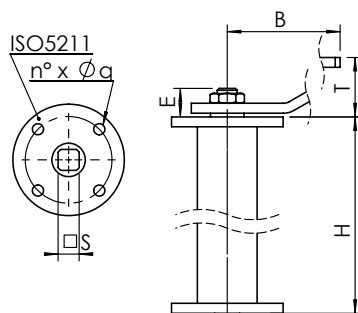

DN	40	50	65	80	100	125	150
H	250-500-800-1000						
T	48	48	48	48	48	59	59
B	230	230	230	280	360	450	560
ISO 5211	F05	F05	F05	F07	F07	F10	F10
J	50	50	50	70	70	102	102
n° x Ø q	4x7	4x7	4x7	4x9	4x9	4x11	4x11
E	22	22	22	23	23	27	27
S	14	14	14	17	17	22	22

KPRB

Prolunga per presa stradale / Stem extension for water main system connection

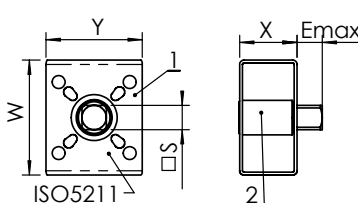
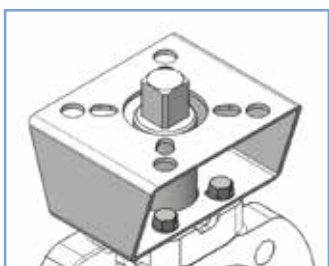

- 1) Flangia / Bracket
- 2) Giunto / Joint

DN	15-20	25-32	40-50-65	80	100	125	150
ISO 5211'	F04-05-07	F04-05-07	F05-07	F10-12	F10-12	F10-12	F10-12-14
S x E	14 x 14	17 x 17	17 x 17	22 x 22	27 X 27	27 X 27	36 X 36
S1 x E1''	11 x 11	11 x 11	-	-	-	-	-
Foratura lato valvola Drilling valve side	F03-04	F03-04	F05-07	F07-10	F07-10	F07-10	F10-12-14
X	40	40	50	60	60	60	80
Y	70	70	70	120	120	120	140
W	80	80	100	120	120	120	160

KISO.B2

Kit flangia ISO 5211 / Kit ISO 5211 flange

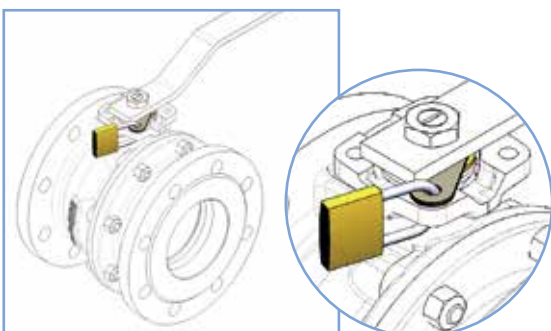

Kit leva di manovra lucchettabile
Kit lockable operation lever

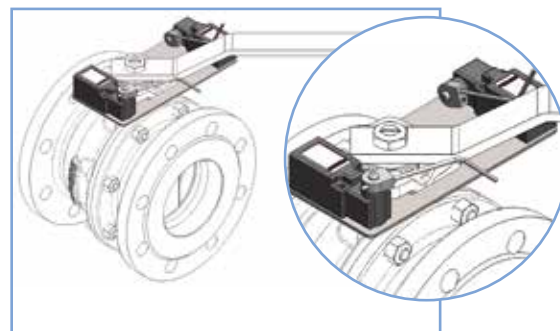

KFC

Kit interruttori di finecorsa per segnalazione Aperto/Chiuso
Kit limit switches for ON/OFF position indicator

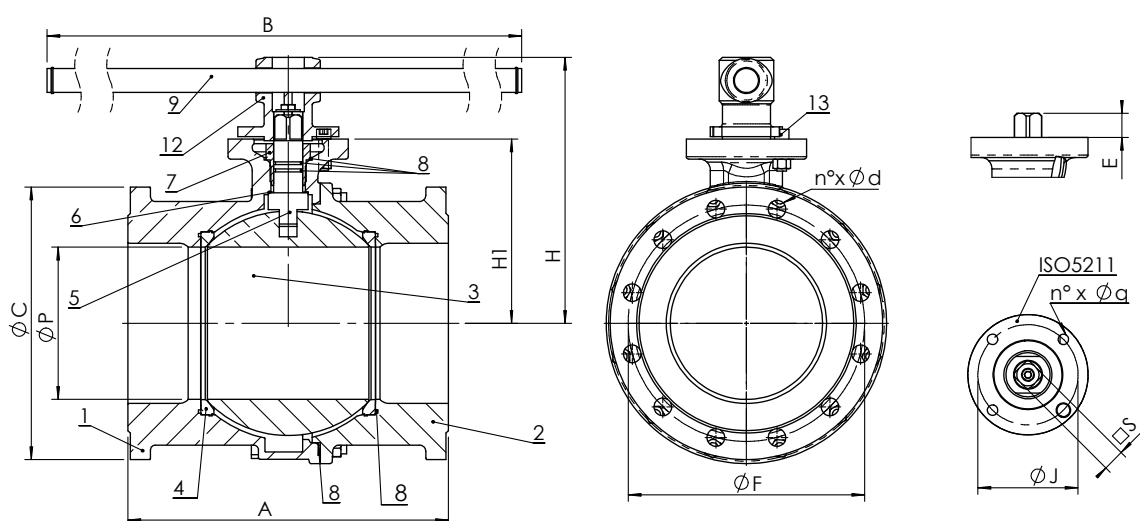
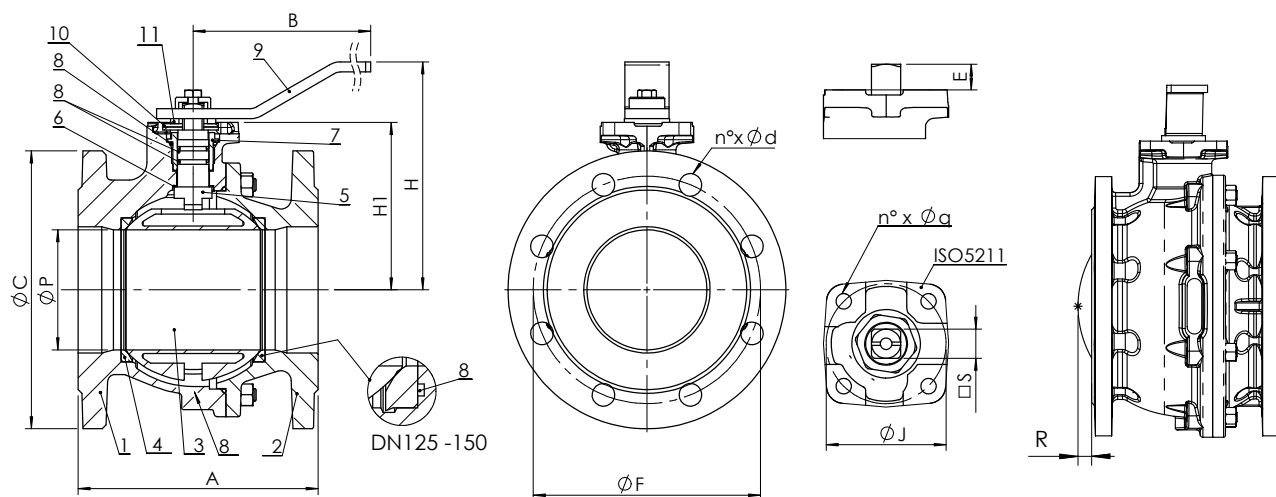

B2.3 - Dimensioni (mm) / Dimensions (mm)

DN		15	20	25	32	40	50	65	80	100	125	150	200	250
P		15	20	25	32	40	50	63	76	95	120	145	190	240
A	EN 558/1 - 14 (ex DIN 3202 F4)	115	120	125	130	140	150	170	180	190	200	210	-	-
A	EN 558/1 - 14 (ex DIN 3202 F5)	-	-	-	-	-	-	-	-	-	-	-	400	450
A	ANSI B16.10 long pattern	-	-	-	-	-	-	-	-	305	-	-	-	-
H		84	84	96	101	125	135	143	165	180	225	243	320	-
H1		50,5	52	59	64	78,5	87	95	118	132,5	165	182,5	230	355
B		160	160	170	170	230	230	230	280	360	520	520	1'000	101
ISO 5211		F04	F04	F04	F04	F05	F05	F05	F07	F07	F10	F10	F12	F12
J		42	42	42	42	50	50	50	70	70	102	102	125	125
n° x Øq		4 x 6	4 x 6	4 x 6	4 x 6	4 x 7	4 x 7	4 x 7	4 x 9	4 x 9	4 x 11	4 x 11	4 x 13	4 x 13
E		9,5	9,5	11	11	13,5	13,5	13,5	15	15	21	21	27	92
S		□ 9	□ 9	□ 11	□ 11	□ 14	□ 14	□ 14	□ 17	□ 17	□ 22	□ 22	□ 27	□ 45
R*		-	-	-	-	-	-	-	-	-	-	7	-	-

Dimensioni flange EN 1092 PN16 - Flanges dimensions EN 1092 PN16

C		95	105	115	140	150	165	185	200	220	250	285	340	405
F		65	75	85	100	110	125	145	160	180	210	240	295	355
n° x Fd		4 x 14	4 x 14	4 x 14	4 x 18	4 x 18	4 x 18	4 x 18	8 x 18	8 x 18	8 x 18	8 x 22	12 x 22	12 x 26

Dimensioni flange ANSI B16.5#150 - Flanges dimensions ANSI B16.5#150

C		88,9	98,6	108	117,3	127	152,4	177,8	190,5	228,6	254	279,4	-	-
F		60,5	69,9	79,2	88,9	98,6	120,7	139,7	152,4	190,5	215,9	241,5	298,5	362
n° x Ød		4 x 16	4 x 16	4 x 16	4 x 16	4 x 16	4 x 19	4 x 19	4 x 19	8 x 19	8 x 22	8 x 22	8 x 22	12 x 26

* R= sporgenza della sfera in posizione chiusa dal piano della flangia (dal lato corpo)

* R= Ball in closing position protrudes from flange plane (body side)

B2.3 - Peso (kg) / Weight (kg)

B2.300		2,8	3,4	4,8	5,6	7,9	10,5	15,1	19,1	24,0	36,7	44,6	104,0	120,0
B2.322		2,8	3,4	4,8	6,5	9,3	11,5	16,0	20,6	28,4	41,2	51,7	131,0	140,0
ANSI	ANSI B16.10 long pattern	-	-	-	-	-	-	-	-	31	-	-	-	-

B2.3 - Coppia di manovra (Nm) / Operating torque (Nm)

Nm		15	15	18	18	18	20	40	70	100	180	250	600	2'000
----	--	----	----	----	----	----	----	----	----	-----	-----	-----	-----	-------

N.B. al fine di ottimizzare la scelta del servocomando si consiglia di moltiplicare il momento torcente per il coefficiente di sicurezza K=1.5
 N.B.: In order to choose the right actuator, we recommend multiplying the operating torque figure by a safety coefficient, K=1.5

B2.3 - Foratura / Drilling

Articolo/item	DN	15	20	25	32	40	50	65	80	100	125	150	200	250
B2.3...16CV Dim. flangia in accordo PN 16 EN1092/3 Dimensions of flanges according to PN 16 EN1092/3	Foratura PN 16 EN1092/1 Drilling PN 16 EN1092/1	std	std	std	std	std	std	std	std	std	std	std	std	std
	Foratura PN 10 EN1092/1 Drilling PN 10 EN1092/1	=	=	=	=	=	=	=	=	=	=	=	opt	opt
	Foratura PN 6 EN1092/1 Drilling PN 6 EN1092/1	opt	opt	opt	opt	opt	opt	opt	opt	opt	opt	opt (1)	opt	opt
	Foratura PN 25 EN1092/1 Drilling PN 25 EN1092/1	=	=	=	=	=	=	opt	=	no	no	no	no	no
B2.3...A1CV Dim. flangia in accordo ANSI B16.5#150 Dimensions of flanges according to ANSI B16.5#150	Foratura ANSI B16.5 #150 Drilling ANSI B16.5 #150	std	std	std	std	std	std	std	std	std	std	std	-	-

std: standard / opt: opzionale a richiesta / =: uguale a PN16

std: standard / opt: option on request / =: same as PN16

(1) Foro filettato / Threaded hole

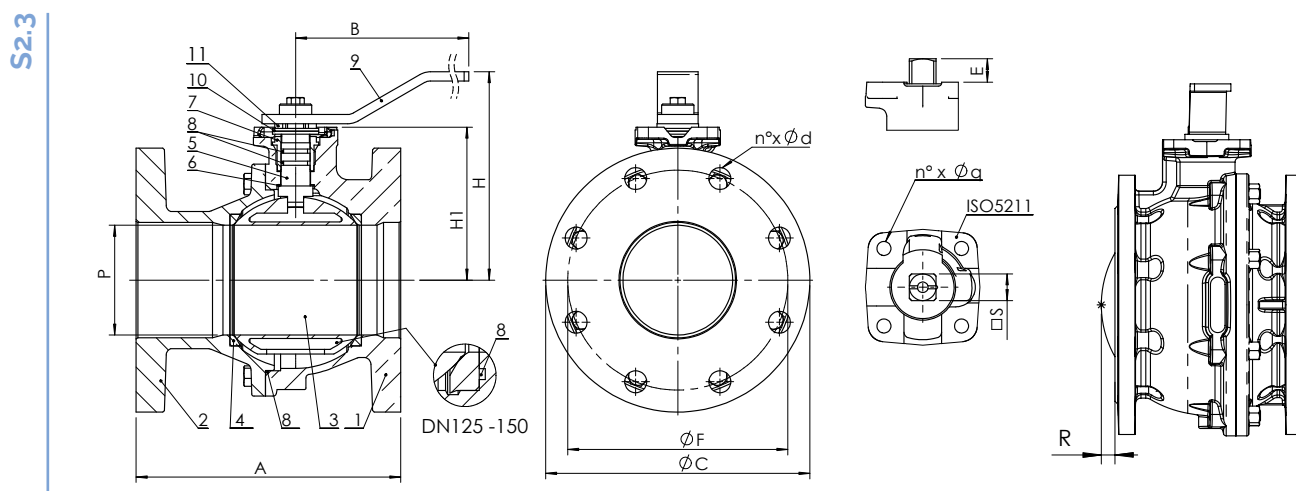

S2.3 - Dimensioni (mm) / Dimensions (mm)

DN		15	20	25	32	40	50	65	80	100	150
P		15	20	25	32	40	50	63	76	95	145
A	ANSI B16.10 #150.Short Pattern	108	117	127	140	165	178	190	203	229	267
H		84	84	96	101	125	135	143	165	180	243
H1		50,5	52	59	64	78,5	87	95	118	132,5	182,5
B		160	160	170	170	230	230	230	280	360	520
ISO 5211		F04	F04	F04	F04	F05	F05	F05	F07	F07	F10
J		42	42	42	42	50	50	50	70	70	102
n° x Øq		4 x 6	4 x 6	4 x 6	4 x 6	4 x 7	4 x 7	4 x 7	4 x 9	4 x 9	4 x 11
E		9,5	9,5	11	11	13,5	13,5	13,5	15	15	21
S		□ 9	□ 9	□ 11	□ 11	□ 14	□ 14	□ 14	□ 17	□ 17	□ 22
R*		-	-	-	-	-	-	-	-	-	7

Dimensioni flange ANSI B16.5#150 - Flanges dimensions ANSI B16.10#150

	15	20	25	32	40	50	65	80	100	150
C	88,9	98,6	108	117,3	127	152,4	177,8	190,5	228,6	279,4
F	60,5	69,9	79,2	88,9	98,6	120,7	139,7	152,4	190,5	241,5
n° x Ød	4 x 16	4 x 16	4 x 16	4 x 16	4 x 16	4 x 19	4 x 19	4 x 19	8 x 19	8 x 22

* R= sporgenza della sfera in posizione chiusa dal piano della flangia (dal lato corpo)

* R= Ball in closing position protrudes from flange plane (body side)

S2.3 - Peso (kg) / Weight (kg)

	15	20	25	32	40	50	65	80	100	150
S2.300	2,1	2,7	4,1	4,9	7,1	9,8	13,9	18	25,7	47,2
S2.322	2,4	3,1	4,7	5,72	8,1	11,3	16	20,8	29,5	56,8

S2.3 - Coppia di manovra (Nm) / Operating torque (Nm)

Nm	15	20	25	32	40	50	65	80	100	150
	15	15	18	18	18	20	40	70	100	250

N.B. al fine di ottimizzare la scelta del servocomando si consiglia di moltiplicare il momento torcente per il coefficiente di sicurezza K=1,5

N.B.: In order to choose the right actuator, we recommend multiplying the operating torque figure by a safety coefficient, K=1.5

R2.3

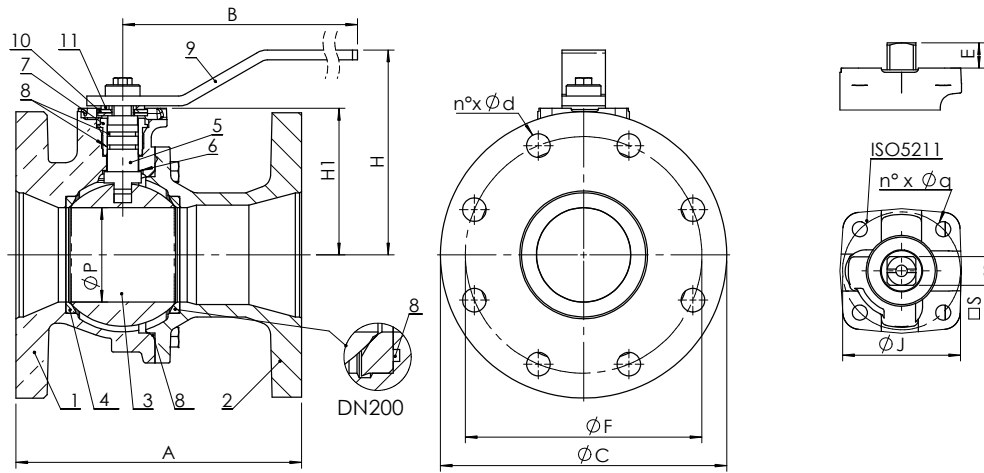

R2.3 - Dimensioni (mm) / Dimensions (mm)

DN		50	80	100	150	200
P		40	50	76	95	145
A	ANSI B16.10 #150.Short Pattern	178	203	229	267	292
H		125	135	165	180	243
H1		78,5	87	118	132,5	182,5
B		230	230	280	360	520
ISO 5211		F05	F05	F07	F07	F10
J		50	50	70	70	102
n° x Fq		4 x 7	4 x 7	4 x 9	4 x 9	4 x 11
E		17,5	17,5	20	20	21
S		□ 14	□ 14	□ 17	□ 17	□ 22

Dimensioni flange ANSI B16.5#150 - Flanges dimensions ANSI B16.10#150

C		152,4	190,5	228,6	279,4	349,2
F		120,7	152,4	190,5	241,5	298,5
n° x Ød		4 x 19	4 x 19	8 x 19	8 x 22	8 x 22

R2.3 - Peso (kg) / Weight (kg)

R2.377		9,4	15,5	24,8	36,2	76,0
--------	--	-----	------	------	------	------

R2.3 - Coppia di manovra (Nm) / Operating torque (Nm)

Nm		18	20	70	100	250
----	--	----	----	----	-----	-----

N.B. al fine di ottimizzare la scelta del servocomando si consiglia di moltiplicare il momento torcente per il coefficiente di sicurezza K=1,5

N.B.: In order to choose the right actuator, we recommend multiplying the operating torque figure by a safety coefficient, K=1.5

Materiali / Materials

	Componente / Component	Materiale / Material		
		B2.300 / S2.300	B2.322 / S2.322	B2.377 / S2.377 / R2.377
1	Corpo/Body	Bronzo / Bronze C83600 ASTM B62 (equiv. CuSn5Zn5Pb5 CC491K EN1982)		
2	Flangia/Flange	Bronzo / Bronze C83600 ASTM B62 (equiv. CuSn5Zn5Pb5 CC491K EN1982)		
3	Sfera DN15-50/Ball DN15-50	Ottone / Brass CuZn40Pb2	Acciaio inox / Stainless steel AISI316	Bronzo all. / Alu bronze CuAl- 10Ni5Fe5
	Sfera DN65-250/Ball DN65-250	Ottone / Brass CuZn40Pb2	Acciaio inox / Stainless steel AISI316	Bronzo alluminio / Alu bronze
4	Sede sfera/Ball seat	PTFE + Carbone / Carbon reinforced PTFE	PTFE + Carbone / Carbon reinforced PTFE	C95800 ASTM B148 PTFE + Carbone / Carbon reinforced PTFE
5	Asta/Stem	Ottone / Brass CuZn40Pb2	Acciaio inox / Stainless steel AISI316	Bronzo alluminio / Alu bronze CuAl10Ni5Fe4
6	Anello antifrizione/Sli- ding Ring	PTFE		
7	Ghiera/Ring nut	Ottone / Brass CuZn40Pb2	Acciaio inox / Stainless steel AISI316	Bronzo alluminio / Alu bronze CuAl10Ni5Fe4
8	O Ring/	FKM (Viton®)		
9	Leva/Handle	Acciaio al carbonio, verniciato epossidico / Carbon steel epoxy coated (1)		
10	Piastrina fermo/Stop plate	Acciaio al carbonio zincato / Carbon steel galvanized (1)		
11	Anello elastico/Spring washer	Acciaio al carbonio zincato / Carbon steel galvanized (1)		
12	Mozzo leva/Handle support (DN200)	Ottone / Brass CuZn40Pb2		
13	Fermo leva /Handle stop (DN200)	Acciaio al carbonio zincato / Carbon steel galvanized (1)		
14	Anello antiestrazione/ Retaining ring (DN250)	Acciaio inox / Stainless steel AISI302		
15	Supporto per riduttore/ Gear box bearing (DN250)	Bronzo alluminio / Aluminium bronze CuAl10Ni5Fe5		
16	Riduttore manuale/ Gear box (DN250)	Acciaio al carbonio zincato / Carbon steel galvanized (1)		
	Bulloneria/Nuts and bolts	Acciaio inox / Stainless steel AISI316		

1: a richiesta in acciaio inox AISI 316

1: AISI 316 stainless steel on request

Pressione massima / Maximum pressure

Tipo fluido * Fluids *	Montaggio Mounting	
	TRA FLANGE BETWEEN FLANGES	FINE LINEA END OF LINE
Gas pericolosi G1 Hazardous gases G1	NO	NO
Liquidi pericolosi L1 Hazardous liquids L1	16 bar DN15-200 10 bar DN250	10 bar
Gas non pericolosi G2 Non hazardous gases G2	16 bar DN15-200 10 bar DN250	10 bar
Liquidi non pericolosi G2 Non hazardous liquids G2	16 bar	10 bar
Acqua** Water**	16 bar	16 bar

* gas, liquidi pericolosi secondo 2014/68/EU e 1272/2008 (CLP)

** Per la raccolta, distribuzione e deflusso di acqua (PED 2014/68/EU 1.1.2b)

* hazardous gas, liquids acc. 2014/68/EU e 1272/2008 (CLP)

** For supply, distribution and discharge of water (PED 2014/68/EU 1.1.2b)

Temperatura / Temperature

Temperatura Temperature	min °C	max°C - Max°C	
		continuo continuous	picco peak
FKM (Viton®)	-10	150	170

Attenzione: la pressione massima di utilizzo diminuisce con la temperatura, vedi diagramma "Pressione/Temperatura"
NB: the maximum working pressure decreases while the temperature increases; please refer to "pressure/temperature" chart

Diagramma Pressione/Temperatura - Pressure/temperature chart

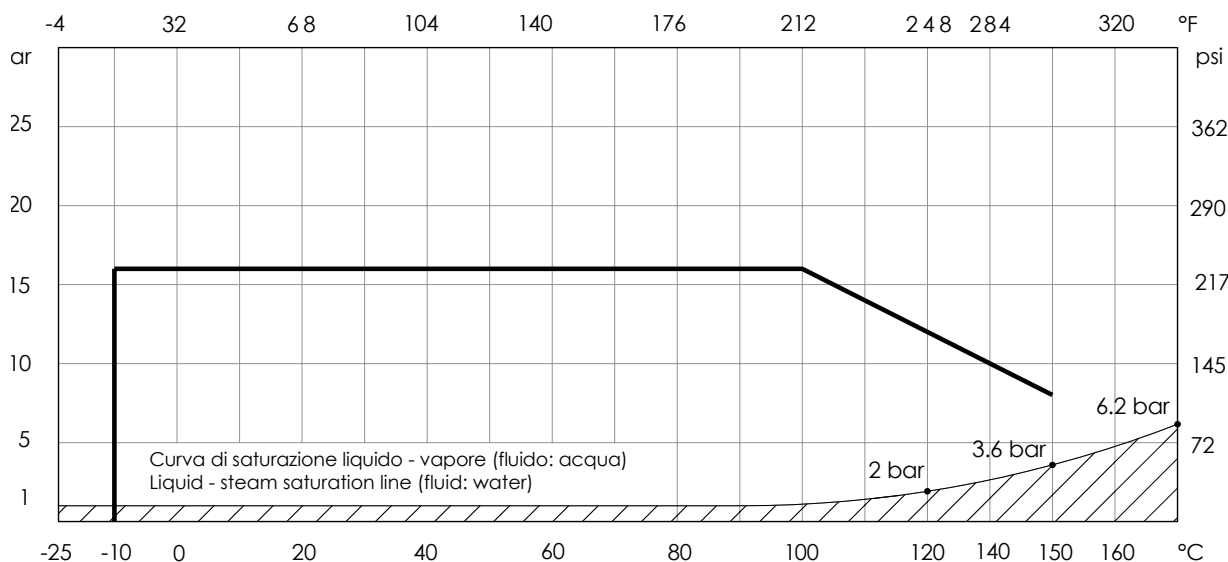

NON ADATTA PER VAPORE. NON utilizzare in condizioni di temperatura e pressione al di sotto della curva di saturazione liquido-vapore (area tratteggiata)
RANGE NOT SUITABLE FOR STEAM. DO NOT use when temperature and pressure are below the liquid-steam saturation line (hatched area)



Perdite di carico Fluido: acqua (1m H₂O = 0,098bar) - Head loss Fluid: water (1m H₂O = 0,098bar)

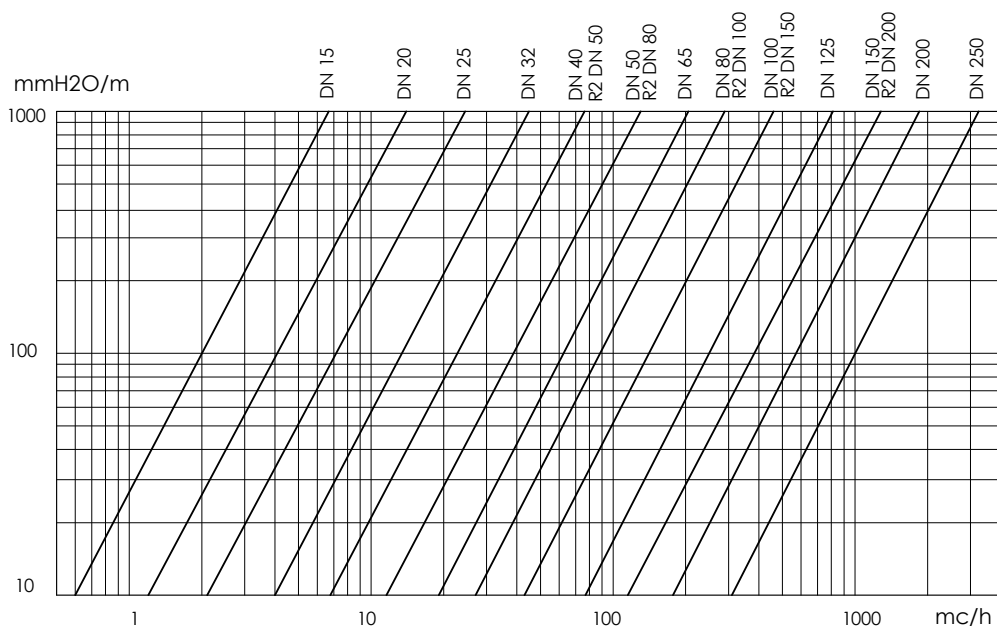

Tabella Kv - DN / Kv - DN chart

DN			15	20	25	32	40	50	65	80	100	125	150	200	250
Kv	B2-S2	mc/h	22.3	47.7	83.5	150.4	255	435	672	947	1'508	2'633	4'261	5'957	10'510
Kv	R2	mc/h						255		435	947		1'508	4'261	

I dati e le caratteristiche di questo catalogo sono forniti a titolo indicativo. La Brandoni S.p.A. si riserva di modificare una o più caratteristiche delle valvole senza preavviso. Per maggiori informazioni www.brandonivalves.com.

Brandoni SpA reserves the right to make changes in design and/or construction of the products at any time without prior notice. For further information, please refer to www.brandonivalves.com